

# Solutions for Transfer Switching

Ed. 1

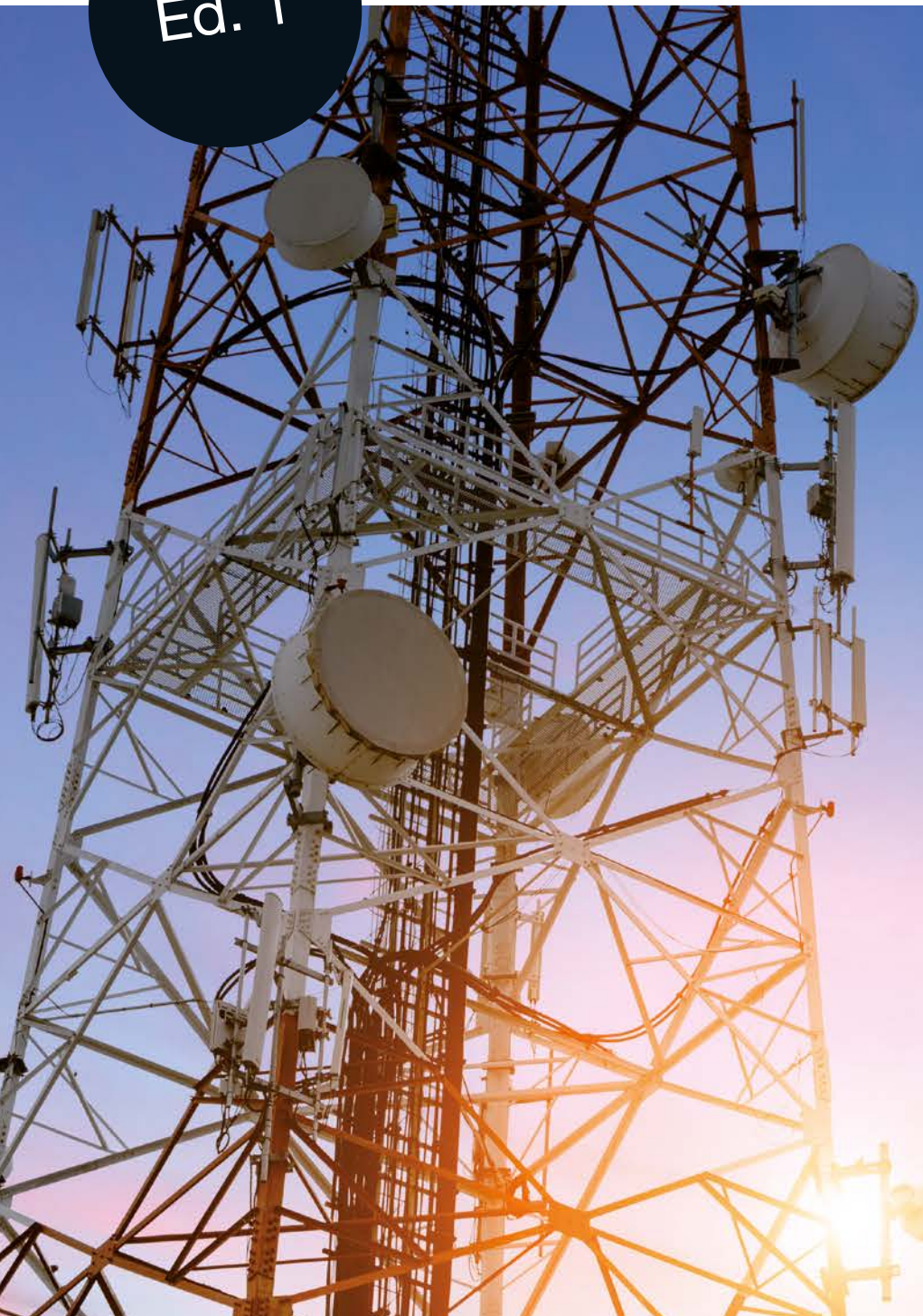

When **energy** matters



# ATyS UL 1008

## Non-automatic Transfer Switching Equipment from 100 to 1200 A

Transfer switches



### Function

**ATyS non-automatic transfer switches** are designed for use in total system optional standby applications for the safe transfer between a normal and an alternate power source.

The changeover is done in open transition and with minimum supply interruption during transfer ensuring full compliance with UL 1008 and IEC 60947-6-1. The ATyS is a full on-load disconnecter where the main components are based on proven technology also meeting requirements in UL 98 and IEC 60947-3 standards.

### Advantages

#### Robust and Reliable design

ATyS is a remotely operated transfer switch tested in full compliance with UL 1008. The design integrates a failsafe mechanical interlock to ensure that the main source is never inadvertently connected to the alternate. The stable position design ensures that the switch is unaffected by vibration or network voltage perturbation. The ATyS also includes a removable handle for on load manual operation. This is extremely safe and easy to use. The ATyS also includes a fully rated switched neutral pole.

#### Maintenance free

The self-cleaning contacts of the ATyS allow the power section to be maintenance free. For safe downstream maintenance the ATyS includes a facility for isolation and padlocking in the zero position.

In the unlikely event of a motorization failure, the ATyS is designed in a way that the motorization can be replaced easily and very quickly. Furthermore, the ATyS remains manually operational with or without the motorization in place.

#### Compatible with virtually any ATS controls

The ATyS is directly compatible with virtually any transfer switching control solution that provides volt free contacts. This allows the ATyS to be combined with most ATS controls available on the market and then used in automatic transfer switch applications.

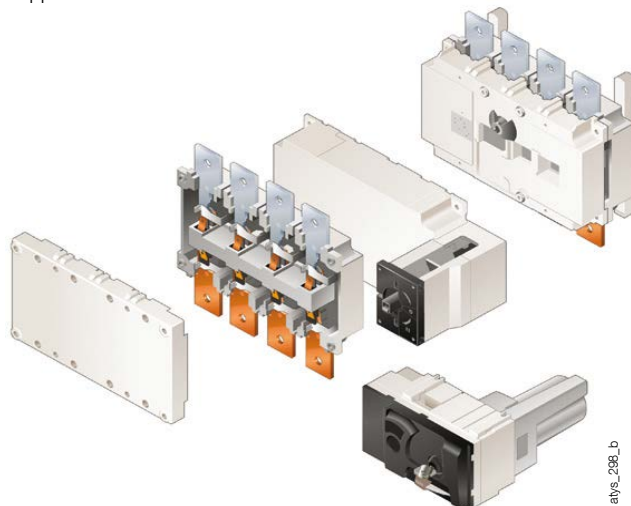

### The solution for

- > Commercial
- > Light Industry
- > Residential applications



### Strong points

- > Robust and reliable design
- > Compatible with virtually any ATS controller
- > On-load manual operation
- > Maintenance free

### Conformity to standards

- > UL 1008 guide WPYV file 317092



*Product reference on request.*

### Your choice of ATS controls

- > Your preferred brand of ATS controller, genset/AMF controller or power/building management system, may easily be paired with the ATyS to provide a complete automatic transfer switch that perfectly suits your needs.

### Typical applications

The ATyS UL 1008 range provides safe transfer for mains/mains, mains/genset and genset/genset applications.

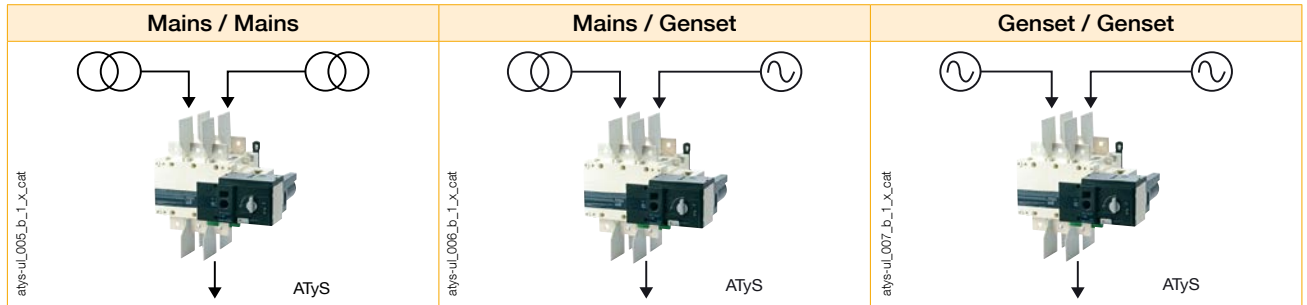

### Part of a globally recognized range

The ATyS UL 1008 is part of a large family of products including a complete range of remotely operated and fully automatic transfer switches that comply to IEC and GB standards.

The ATyS range is a world renowned product family trusted by some of the largest manufacturers in the genset industry.

The key to success has been through reliable power availability provided by products that are safe and easy to use.

ATyS r	ATyS d	ATyS t	ATyS g	ATyS p
<ul style="list-style-type: none"> <li>UL</li> <li>IEC</li> <li>CCC</li> </ul>	<ul style="list-style-type: none"> <li>IEC</li> <li>CCC</li> </ul>	<ul style="list-style-type: none"> <li>IEC</li> <li>CCC</li> </ul>	<ul style="list-style-type: none"> <li>IEC</li> <li>CCC</li> </ul>	<ul style="list-style-type: none"> <li>IEC</li> <li>CCC</li> </ul>
Remote Transfer Switch	Remote Transfer Switching (RTS)	Automatic Transfer Switching (ATS)	Automatic Transfer Switching (ATS)	Automatic Transfer Switching (ATS)
Remote Transfer Switch	Dual power supply	Automatic controller to manage mains/mains applications	Automatic controller to manage mains/genset applications	Functions for energy management Communication options

WEB SERVER OPTION

Please don't hesitate to contact SOCOMEC with any questions regarding the IEC ATyS range of products above rated from 125 to 3200 A.



# ATyS UL 1008

Non-automatic Transfer Switching Equipment

from 100 to 1200 A

## References

### ATyS UL 1008

Rating (A)	Frame size	No. of poles	ATyS	Bridging bars	Terminal screens	Auxiliary contact	Lug kits		
100 A	B4	2 P	9723 <b>2010</b>	2 P 4159 <b>2021</b>	2/3 P 4158 <b>3021</b>	NO/NC 4159 <b>0021</b>	2 P 3954 <b>2020</b>		
		3 P	9723 <b>3010</b>					3 P	3 P
		4 P	9723 <b>4010</b>					4 P	3954 <b>3020</b>
200 A		2 P	9723 <b>2020</b>	4 P	4158 <b>4021</b>		4 P 3954 <b>4020</b>		
		3 P	9723 <b>3020</b>	4 P	4159 <b>4021</b>				
		4 P	9723 <b>4020</b>						
260 A	B5	2 P	9723 <b>2026</b>	2 P 4159 <b>2041</b>	2 / 3 P 4158 <b>3041</b>	Low level 4159 <b>0022</b>	2 P 3954 <b>2040</b>		
		3 P	9723 <b>3026</b>					3 P	3 P
		4 P	9723 <b>4026</b>					4 P	3954 <b>3040</b>
400 A		2 P	9723 <b>2040</b>	4 P	4159 <b>4041</b>		4 P 3954 <b>4040</b>		
		3 P	9723 <b>3040</b>	4 P	4158 <b>4041</b>				
		4 P	9723 <b>4040</b>						
600 A	B6	3 P	9723 <b>3060</b>	4159 <b>3063</b>	1609 <b>3063</b>		3954 <b>3060</b>		
		4 P	9723 <b>4060</b>	4159 <b>4063</b>	1609 <b>4063</b>		3954 <b>4060</b>		
800 A	B7	3 P	9723 <b>3080</b>	3 P 4159 <b>3080</b>	3 P 1609 <b>3080</b>	Contact NO/NC as Standard	3 P 3954 <b>3120</b>		
		4 P	9723 <b>4080</b>					4 P	4 P
		3 P	9723 <b>3120</b>					4 P	4 P
1200 A		4 P	9723 <b>4120</b>	4159 <b>4080</b>	1609 <b>4080</b>		3954 <b>4120</b>		

Common accessories - more available on next pages.

### Accessories

#### Terminal screens

Rating (A)	No. of poles	Reference
100 ... 200	2/3 P	4158 <b>3021</b>
100 ... 200	4 P	4158 <b>4021</b>
260 ... 400	2/3 P	4158 <b>3041</b>
260 ... 400	4 P	4158 <b>4041</b>
600	3 P	1609 <b>3063</b>
600	4 P	1609 <b>4063</b>
800 ... 1200	3 P	1609 <b>3080</b>
800 ... 1200	4 P	1609 <b>4080</b>

#### Use

Top and bottom protection against direct contact with terminals or connecting parts.



access\_207\_a\_2\_cat

#### Bridging bars

Rating (A)	No. of poles	Reference
100 ... 200	2 P	4159 <b>2021</b>
100 ... 200	3 P	4159 <b>3021</b>
100 ... 200	4 P	4159 <b>4021</b>
260 ... 400	2 P	4159 <b>2041</b>
260 ... 400	3 P	4159 <b>3041</b>
260 ... 400	4 P	4159 <b>4041</b>
600	3 P	4159 <b>3063</b>
600	4 P	4159 <b>4063</b>
800 ... 1200	3 P	4159 <b>3080</b>
800 ... 1200	4 P	4159 <b>4080</b>

#### Use

For bridging power terminals on the top or bottom side of the switch. When ordering one reference is required per switch. Please check numbers of poles needed.

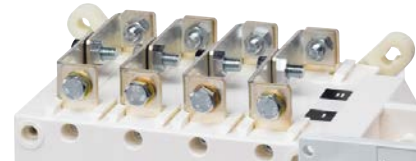

access\_205\_a\_2\_cat

#### Auxiliary contacts

##### Use

Pre-break and signalling of positions I and II: each reference provides 1 NO/NC auxiliary contact for positions I and II. ATyS are supplied with 1 NO auxiliary contact for all three positions as standard.

Rating (A)	Contact (s)	Reference
100 ... 400	NO/NC on position 1 and 2	4159 <b>0021</b>
100 ... 400	Low level NO/NC on position 1 and 2	4159 <b>0022</b>
600 ... 1200	NO/NC on position 1 and 2	as standard

A maximum of 2 Aux contacts per position may be added.



access\_065\_a\_1\_cat



access\_065\_a\_1\_cat

#### Terminal lugs

##### Use

Connection of bare copper cables onto the terminals (without lugs).

Rating (A)	Wires range	No wires per lug	Lugs per kit	Wires	Reference
100 ... 200	6 - 300MCM	1	2	Cu / Al	3954 <b>2020</b>
100 ... 200	6 - 300MCM	1	3	Cu / Al	3954 <b>3020</b>
100 ... 200	6 - 300MCM	1	4	Cu / Al	3954 <b>4020</b>
260 ... 400	4 - 600MCM	1	2	Cu / Al	3954 <b>2040</b>
260 ... 400	4 - 600MCM	1	3	Cu / Al	3954 <b>3040</b>
260 ... 400	4 - 600MCM	1	4	Cu / Al	3954 <b>4040</b>
600	2x (#2 - 600MCM)	2	3	Cu / Al	3954 <b>3060</b>
600	2x (#2 - 600MCM)	2	4	Cu / Al	3954 <b>4060</b>
800 ... 1200 <sup>(1)</sup>	2x 2x(#2 - 600MCM)	2	6	Cu / Al	3954 <b>3120</b>
800 ... 1200 <sup>(1)</sup>	2x 2x(#2 - 600MCM)	2	8	Cu / Al	3954 <b>4120</b>

(1) To be used to connect 4 wires on one terminal. In such a case, 2 lugs are placed side-by-side on one terminal. Please refer to dimensions diagram



ul\_032\_a

# ATyS UL 1008

Non-automatic Transfer Switching Equipment  
from 100 to 1200 A

## Spares

### Motorization module

Rating (A)	No. of poles	Frame size	Used for ATyS reference	Motorization module References
100	2 / 3 / 4 P	B4	9723 2010 - 9723 3010 - 9723 4010	9709 5010
200	2 / 3 / 4 P		9723 2020 - 9723 3020 - 9723 4020	9709 5020
260	2 / 3 / 4 P	B5	9723 2026 - 9723 3026 - 9723 4026	9709 5026
400	2 / 3 / 4 P		9723 2040 - 9723 3040 - 9723 4040	9709 5040
600	3 / 4 P	B6	9723 3060 - 9723 4060	9709 5060
800	3 / 4 P	B7	9723 3080 - 9723 4080	9709 5080
1200	3 / 4 P		9723 3120 - 9723 4120	9709 5120



atys\_b71\_a\_1\_cat.eps

### Terminal lugs (in/mm)

#### 100 and 200 A / B4

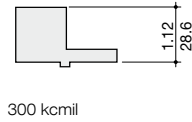
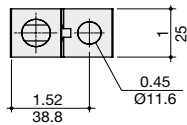

sirco\_115\_b\_1\_us\_cat

#### 260 and 400 A / B5

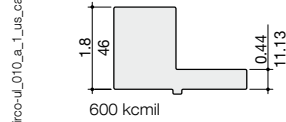
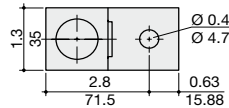

sirco-ul\_010\_a\_1\_us\_cat

#### 600 to 1200 A / B6 - B7

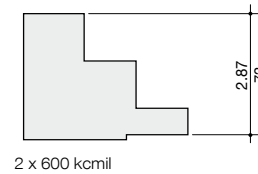
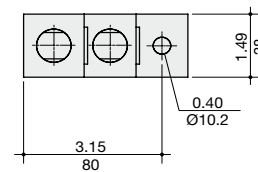

sirco\_116\_b\_1\_us\_cat

### Mounting orientation

#### 100 to 400 A / B4 - B5

atys-ul\_013 ... 014\_a\_1\_x\_cat

Recommended	OK	Not Allowed	OK

#### 600 to 1200 A / B6 - B7

atys-ul\_013 ... 014\_a\_1\_x\_cat

Recommended	Not Allowed	OK	OK

### Characteristics

#### Characteristics according to UL 1008 (Optional standby)

General use rating (A)	100 A	200 A	260 A	400 A	600 A	800 A	1200 A
<b>Frame size</b>	<b>B4</b>		<b>B5</b>		<b>B6</b>	<b>B7</b>	
Operation voltage 2 P - 3/4 P	240/600	240/600	240/600	240/600	-/600	-/600	-/600
<b>Short circuit rating at 600 VAC with fuses (kA)</b>							
Short circuit rating at 600 VAC (kA)	100	100	65	65	100	100	100
Type of fuse	J	J	J	J	L	L	L
<b>Short circuit rating at 600 VAC with "Specific Circuit Breaker" (kA)</b>							
Square D JJ breaker 250 A - 2 P 240 VAC - 3/4 P 480 VAC	65	65	-	-	-	-	-
Schneider Electric NSX-F 160 A - 3/4 P 480 VAC	35	-	-	-	-	-	-
<b>Short circuit rating at 600 VAC with "Any Breaker" (kA)</b>							
Short circuit rating (kA)	10	10	14	14	35	35	35
Short circuit capacity (ms)	25	25	50	50	50	50	50
<b>Rated operational current</b>							
240 VAC "Total System" (A)	100	200	260	400	400	700	700
240 VAC resistive load (A)	100	200	260	400	600	800	1200
480 VAC "Total System" (A)	100	100	260	400	350	600	600
480 VAC resistive load (A)	100	200	260	400	600	800	1200
600 VAC "Total System" (A)	100	100	200	200	-	-	-
600 VAC resistive load (A)	100	200	260	400	600	800	1200
<b>Mechanical endurance</b>							
Endurance (number of operating cycles)	6050	6050	6050	4050	3050	3050	3050
<b>Connection terminals</b>							
Min. connection section / AWG	#6	#6	#4 / 2 X 1 / 0	#4 / 2 X 1 / 0	2 x #2	2 x #2	4 x #2
Max. connection section / AWG	300MCM	300MCM	600MCM / 2 X 250MCM	600MCM / 2 X 250MCM	2x 600MCM	2x 600MCM	4 x 600MCM
<b>Power supply</b>							
Supply voltage VAC 50/60 Hz	208-277 VAC ± 20%						
<b>Switching time</b>							
I to II or II to I (s)			1.3			3.2	
I to 0 or 0 to II (s)			0.85			1.8	
Duration of electrical blackout (s)			0.6			1.6	

### Terminals and connections

#### Typical wiring for 277/480 VAC and 120/208 VAC networks

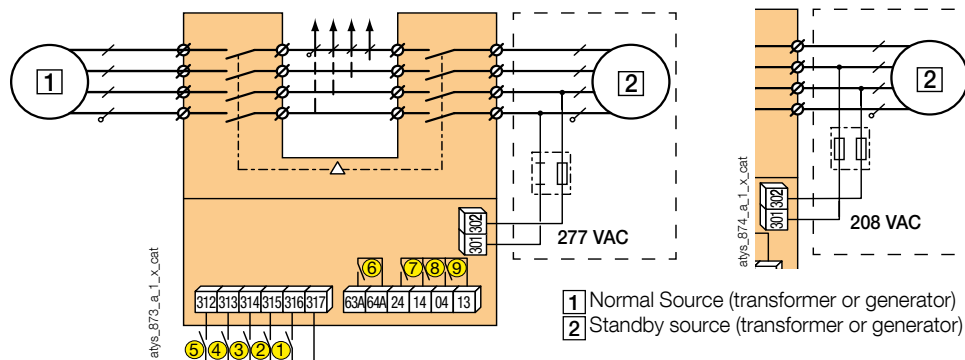

- 1: position 0 order input (contactor logic if closed)
- 2: position I order input
- 3: position II order input
- 4: position 0 priority order input
- 5: Input to enable or disable inputs 1 to 4

- 6: product availability relay, (watchdog)
- 7: auxiliary contact, closed when the switch is in position II
- 8: auxiliary contact, closed when the switch is in position I
- 9: auxiliary contact, closed when the switch is in position 0

# ATyS UL 1008

## Non-automatic Transfer Switching Equipment

from 100 to 1200 A

### Dimensions (in/mm)

100 to 400 A / B4 - B5

#### Transfer switch dimensions

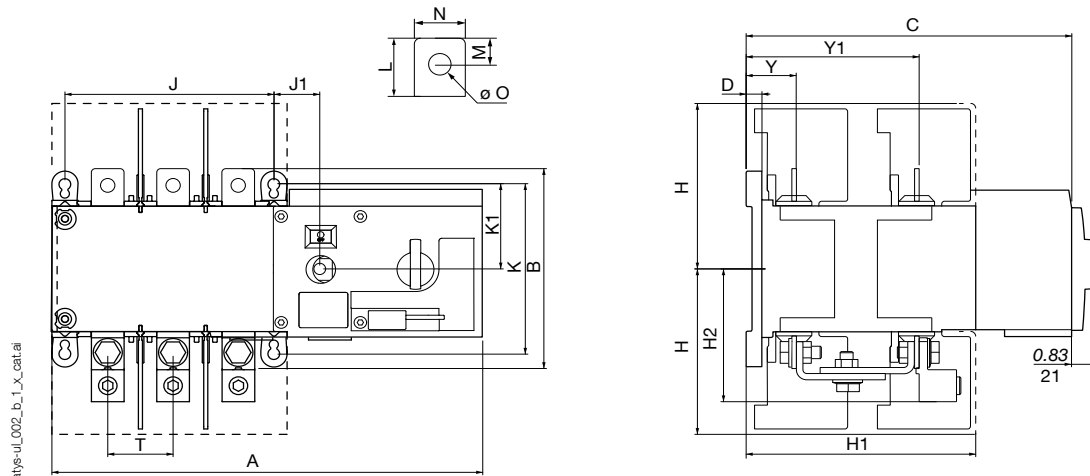

Rating (A)	Frame size	Reference	No. of poles	A		B		C		D		H		H1		H2		Y		Y1		
				in	mm	in	mm	in	mm	in	mm	in	mm	in	mm	in	mm	in	mm	in	mm	in
100 - 200	B4	9723 2010 - 9723 2020	2 P	12.91	328	6.30	160	9.60	244	0.41	10.5	5.08	129	6.93	176	4.21	107	1.51	38.5	5.21	132.5	
		9723 3010 - 9723 3020	3 P																			
		9723 4010 - 9723 4020	4 P	14.88	378																	
260 - 400	B5	9723 2026 - 9723 2040	2 P	14.84	377	10.23	260	12.62	320.5	0.41	10.5	8	203	6.51	165.5	6.53	166	2.04	52	7.48	190	
		9723 3026 - 9723 3040	3 P																			
		9723 4026 - 9723 4040	4 P	17.20	437																	

Rating (A)	Frame size	Reference	No. of poles	J		J1		K		K1		L		M		N		O		T	
				in	mm	in	mm	in	mm	in	mm	in	mm	in	mm	in	mm	in	mm	in	mm
100 - 200	B4	9723 2010 - 9723 2020	2 P	6.30	160																
		9723 3010 - 9723 3020	3 P			1.37	35	7.67	195	3.84	97.5	1.18	30	0.53	13.3	0.98	25	0.43	11	2	50
		9723 4010 - 9723 4020	4 P	8.26	210																
260 - 400	B5	9723 2026 - 9723 2040	2 P	8.26	210																
		9723 3026 - 9723 3040	3 P			1.37	35	7.67	195	3.84	97.5	1.96	50	0.49	20	1.38	45	0.51	13	2.6	65
		9723 4026 - 9723 4040	4 P	10.63	270																



100 to 400 A / B4 - B5

Minimum enclosure dimensions

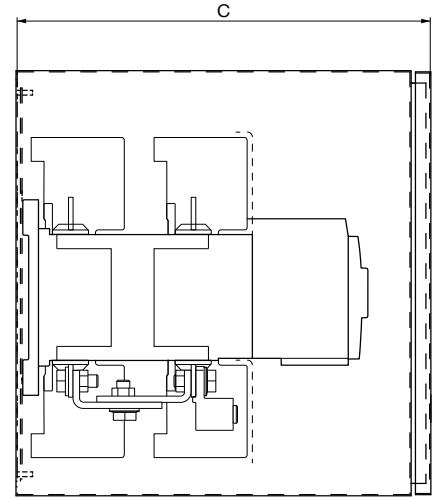
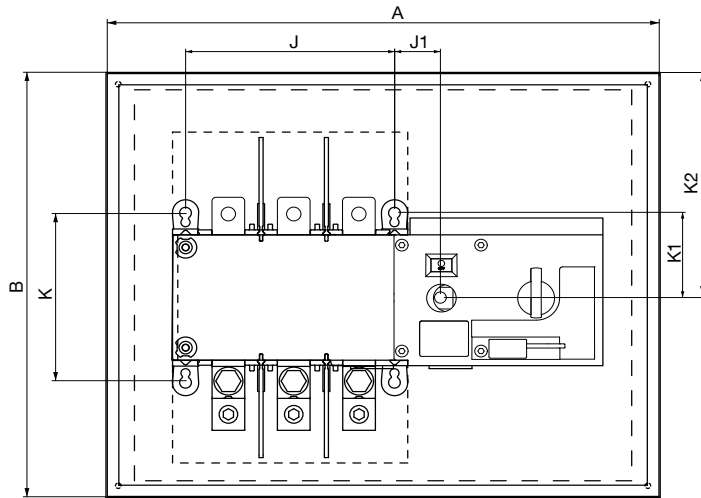

atys-ul\_009\_b\_1\_x\_cat.ai

Door cut-out for front panel

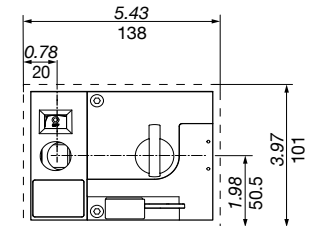

atys-ul\_017\_a\_1\_x\_cat.ai

Rating (A)	Frame size	Reference	No. of poles	A		B		C		J		J1		K		K1		K2		
				in	mm	in	mm	in	mm	in	mm	in	mm	in	mm	in	mm	in	mm	
100 - 200	B4	9723 2010 - 9723 2020	2 P							6.30	160	1.37	35	7.67	195	2.67	68	12	305	
		9723 3010 - 9723 3020	3 P	24	610	24	610	12	305	8.26	210									
		9723 4010 - 9723 4020	4 P																	
260 - 400	B5	9723 2026 - 9723 2040	2 P							8.26	210	1.37	35	7.67	195	3.84	97.5	15	381	
		9723 3026 - 9723 3040	3 P	32	813	32	813	16	406	10.63	270									
		9723 4026 - 9723 4040	4 P																	

## Dimensions (in/mm) (continued)

600 to 1200 A / B6 - B7

### Transfer switch dimensions

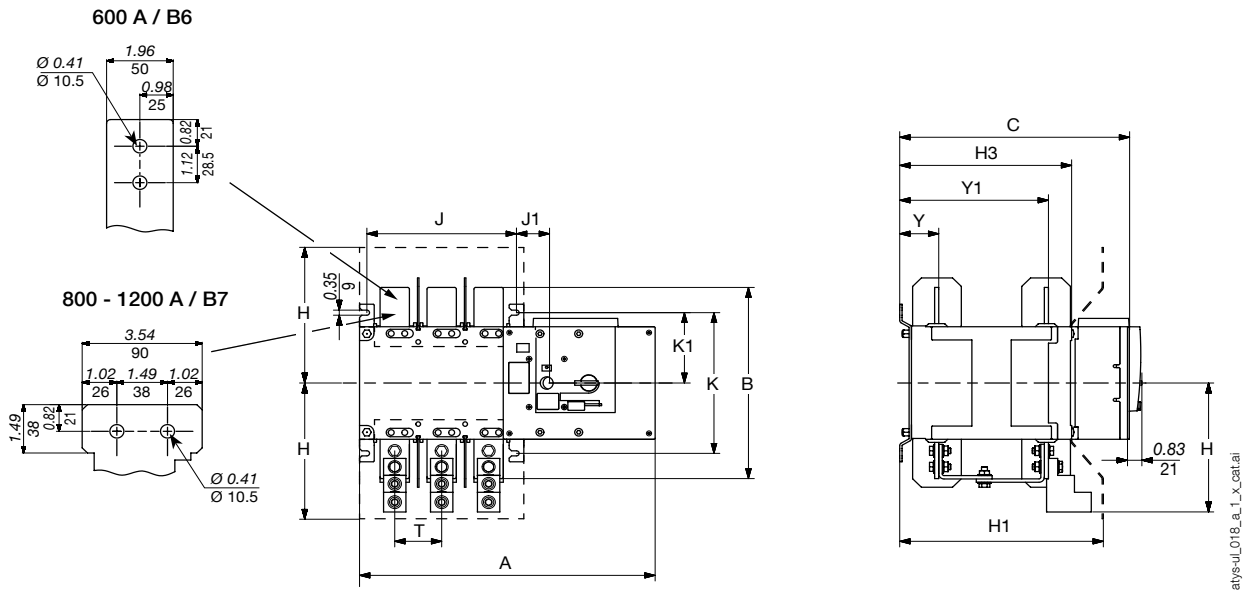

Rating (A)	Frame size	Reference	No. of poles	A		B		C		H		H1		H2		H3	
				in	mm	in	mm	in	mm	in	mm	in	mm	in	mm	in	mm
600	B6	9723 3060	3 P	19.8	504	13.38	340	15.4	392	9.09	231	13.7	347	9.05	230	11.5	293
		9723 4060	4 P	22.99	584												
800 - 1200	B7	9723 3080 - 9723 3120	3 P	23.5	596	11.34	288	15.4	392	8.30	211	13.7	347	8.03	204	11.5	293
		9723 4080 - 9723 4120	4 P	28.2	716												

Rating (A)	Frame size	Reference	No. of poles	J		J1		K		K1		T		Y		Y1	
				in	mm	in	mm	in	mm	in	mm	in	mm	in	mm	in	mm
600	B6	9723 3060	3 P	10	255	2.02	51.5	9.84	250	4.92	125	3.15	80	2.61	66.5	9.98	254
		9723 4060	4 P	13.2	335												
800 - 1200	B7	9723 3080 - 9723 3120	3 P	13.7	347	2.02	51.5	9.84	250	4.92	125	4.72	120	2.65	67.7	9.98	254
		9723 4080 - 9723 4120	4 P	18.4	467												

## 600 to 1200 A / B6 - B7

### Minimum enclosure dimensions

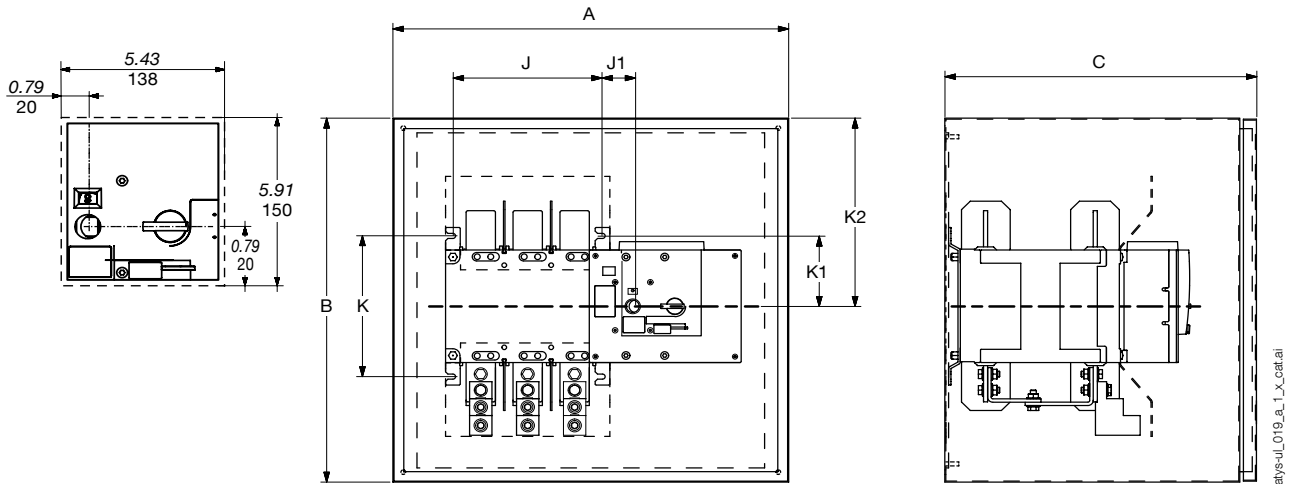

Rating (A)	Frame size	Reference	No. of poles	A		B		C		J		J1		K		K1		K2	
				in	mm	in	mm	in	mm	in	mm	in	mm	in	mm	in	mm	in	mm
600	B6	9723 3060	3 P	36	915	48	1220	20	508	10.04	255	2.02	51.5	9.84	250	4.92	125	24	610
		9723 4060	4 P							12.18	355								
800 - 1200	B7	9723 3080 - 9723 3120	3 P	36	915	60	1524	20	508	13.66	347	2.02	51.5	9.84	250	4.92	125	30	762
		9723 4080 - 9723 4120	4 P							18.38	467								



# SIRCOVER UL 98/1008

Manually operated transfer switching equipment  
from 100 to 1200 A

Transfer switches

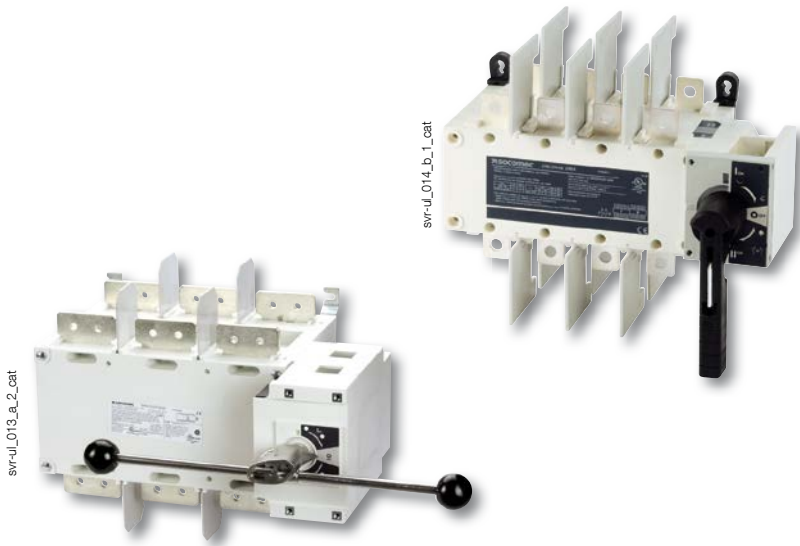

## The solution for

- > Manufacturing industry
- > Power distribution
- > Domestic



## Strong points

- > Stable positions
- > Compact design
- > On-load switching
- > Reliability

## Conformity to standards

- > UL 1008  
guide WPYV  
file 317092
- > UL 98  
guide WHTY  
file 201138
- > CSA 22.2#4  
class 4651-02



*UL 98 and CSA from 600-1200 A. Specific reference from 100 to 400 A on request.*

## Enclosed solutions

SOCOMEc offers a range of pre-equipped enclosures



Enclosed  
SIRCOVER

## Function

**SIRCOVER UL 98/1008** are heavy duty manual transfer switches. They ensure switching transfer of sources or transfer of two low voltage circuits on load as well as their safe disconnection.

These switches are extremely durable and are tested and approved for use in the most demanding applications, such as resistive load or total system applications.

## Advantages

### Stable positions

SIRCOVERs have three stable positions which are not affected by voltage drops or vibrations, thus protecting your load against network interference.

### Compact design

The SIRCOVER are based on a back-to-back switching technology, providing a compact solution.

### On-load switching

The SIRCOVER UL enables secure and reliable switching, without the need for pre-breaking upstream.

### Reliability

The SIRCOVER has double breaking per pole achieved through its sliding bar contacts system.

The quick opening and rapid closure provides simultaneous disconnecting or making of all power contacts.

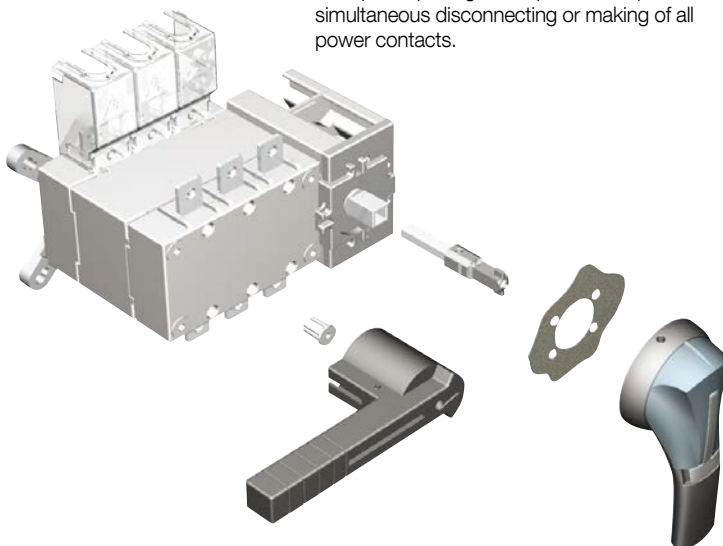

svr\_136\_a\_2\_cat

**Typical application**

The SIRCOVER UL 98/1008 range provides safe transfer and disconnection within your LV installation for optional standby systems (as described in NEC Article 702).

Standard applications also include:

- Transfer from Normal power supply to the backup genset source (emergency supply).
- Safe on load transfer.
- Changing motor phase rotation and equipment grounding connection.

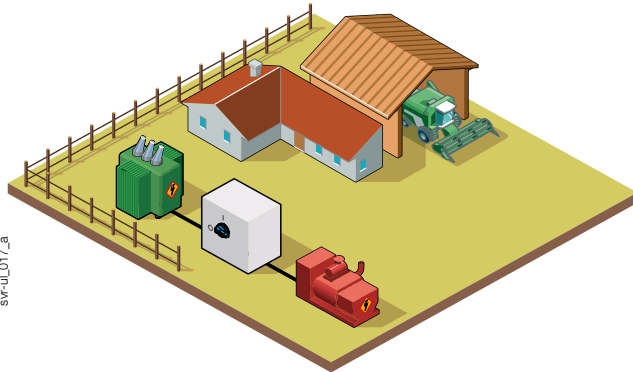

svr-ul\_017\_a

The SIRCOVER UL 98/1008 can also be used as switching means to a temporary power supply in emergency systems (systems needed for human safety) as described in article 700.3(F) of the NEC (see example below "switching means and interlock").

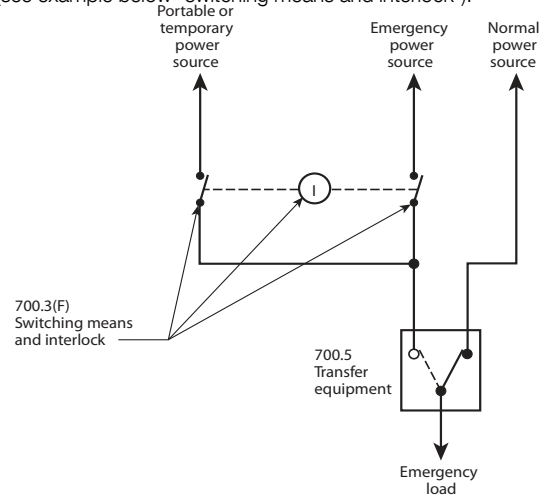

svr-ul\_018\_a\_1\_us\_cat.ai

Example of connection for temporary or portable power <sup>(1)</sup>.

(1) National Fire Protection Agency, NFPA 70: National Electrical Code®, 2017 Edition. Quincy, MA: National Fire Protection Agency, 2016, p. 70–581.

**SOCOMEc solution up to 1200 A**

svr-ul\_014\_b\_2\_cat



**UL 1008 Manual Transfer Switch**

From **100 to 400 A** for resistive and total systems applications.  
 UL 98 / CSA 22.2#4 versions on request.

svr-ul\_013\_a\_2\_cat



**UL 1008 and UL 98 Manual Transfer Switch**

From **600 to 1200 A** for resistive and total systems applications.  
 Has UL 98/CSA 22.2#4 certification.

**IEC solution up to 3200 A**

The SIRCOVER UL 1008 is part of a large range that includes an IEC products of standalone or enclosed manual transfer switches and manual bypass switches with overlapping options. Contact us for further information on our complete range.





# SIRCOVER UL 98/1008

Manually operated transfer switching equipment  
from 100 to 1200 A

## References

### SIRCOVER UL 98/1008

Rating (A)	Frame size	No. of poles	Switch body	Direct handle	External handle	Shaft for external handle	Bridging bars	Auxiliary contacts	Terminal screens									
100 A*	B4	2 P	4150 <b>2012</b>	Black 4199 <b>4012</b>	S2 type Black I - 0 - II 4, 4X 142D <b>2113</b>	S2 type  200 mm 7.9 inches 1400 <b>1020</b>  320 mm 12.6 inches 1400 <b>1032</b>  400 mm 15.7 inches 1400 <b>1040</b>	2 P 4159 <b>2021</b> 3 P 4159 <b>3021</b> 4 P 4159 <b>4021</b>	Contact NO/NC 4159 <b>0021</b> Low level 4159 <b>0022</b>	2 / 3 P 4158 <b>3021</b> 4 P 4158 <b>4021</b>									
		3 P	4150 <b>3012</b>															
		4 P	4150 <b>4012</b>															
200 A*	B5	2 P	4150 <b>2022</b>															
		3 P	4150 <b>3022</b>															
		4 P	4150 <b>4022</b>															
260 A*	B5	2 P	4150 <b>2026</b>	S2 type Black I - 0 - II 4, 4X 142D <b>2113</b>	S2 type  200 mm 7.9 inches 1400 <b>1020</b>  320 mm 12.6 inches 1400 <b>1032</b>  400 mm 15.7 inches 1400 <b>1040</b>	2 P 4159 <b>2041</b> 3 P 4159 <b>3041</b> 4 P 4159 <b>4041</b>	Contact NO/NC 4159 <b>0021</b> Low level 4159 <b>0022</b>	2 / 3 P 4158 <b>3041</b> 4 P 4158 <b>4041</b>										
		3 P	4150 <b>3026</b>															
		4 P	4150 <b>4026</b>															
400 A*	B5	2 P	4150 <b>2042</b>						S3 type Black I - 0 - II 4, 4X 143D <b>3113</b>	S3, S4 type  200 mm 7.9 inches 1401 <b>1520</b>  320 mm 12.6 inches 1401 <b>1532</b>  400 mm 15.7 inches 1401 <b>1540</b>	3 P 4159 <b>3063</b> 4 P 4159 <b>4063</b>	Contact NO/NC as standard	3 P 1609 <b>3063</b> 4 P 1609 <b>4063</b>					
		3 P	4150 <b>3042</b>															
		4 P	4150 <b>4042</b>															
600 A	B6	3 P	4150 <b>3060</b>	S4 type Black I - 0 - II 4, 4X 144D <b>3813<sup>(*)</sup></b>	S4 type Black I - 0 - II 4, 4X 144D <b>3813<sup>(*)</sup></b>	3 P 4159 <b>3080</b> 4 P 4159 <b>4080</b>	Contact NO/NC as standard	3 P 1609 <b>3080</b> 4 P 1609 <b>4080</b>										
		4 P	4150 <b>4060</b>															
800 A	B7	3 P	4150 <b>3080</b>											Black 4199 <b>7062</b>	S4 type Black I - 0 - II 4, 4X 144D <b>3813<sup>(*)</sup></b>	3 P 4159 <b>3080</b> 4 P 4159 <b>4080</b>	Contact NO/NC as standard	3 P 1609 <b>3080</b> 4 P 1609 <b>4080</b>
		4 P	4150 <b>4080</b>															
1200 A	B7	3 P	4150 <b>3120</b>						Black 4199 <b>7062</b>	S4 type Black I - 0 - II 4, 4X 144D <b>3813<sup>(*)</sup></b>	3 P 4159 <b>3080</b> 4 P 4159 <b>4080</b>	Contact NO/NC as standard	3 P 1609 <b>3080</b> 4 P 1609 <b>4080</b>					
		4 P	4150 <b>4120</b>															

Common accessories - more available on next pages.

\* From 100 to 400 A, UL 98 Specific reference upon request.

Direct handle

Rating (A)	Type	Color	Handle type	Reference
100 ... 400	B3	Black	1 lever	4199 <b>4012</b>
600	J4	Black	2 levers	4199 <b>7012</b>
800 ... 1200	V1	Metal	2 levers	4199 <b>7062</b>

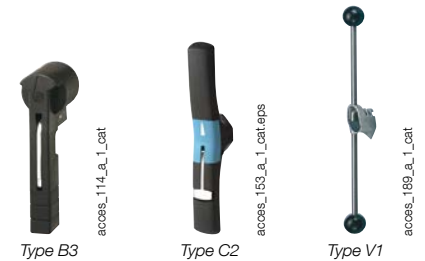

External handle

Rating (A)	Handle type	Color	Nema type	Lockable in 3 positions	Reference
100 ... 400	S2	Black	4, 4X	no	142D <b>2113</b>
100 ... 400	S2	Red/Yellow	4, 4X	no	142E <b>2113</b>
100 ... 400	S2	Black	1, 3R, 12	no	142F <b>2113</b>
100 ... 400	S2	Red/Yellow	1, 3R, 12	no	142G <b>2113</b>
100 ... 400	S2	Black	4, 4X	yes	142D <b>2813</b>
100 ... 400	S2	Red/Yellow	4, 4X	yes	142E <b>2813</b>
100 ... 400	S2	Black	1, 3R, 12	yes	142F <b>2813</b>
100 ... 400	S2	Red/Yellow	1, 3R, 12	yes	142G <b>2813</b>
260 ... 600	S3	Black	4, 4X	no	143D <b>3113</b>
260 ... 600	S3	Red/Yellow	4, 4X	no	143E <b>3113</b>
260 ... 600	S3	Black	1, 3R, 12	no	143F <b>3113</b>
260 ... 600	S3	Red/Yellow	1, 3R, 12	no	143G <b>3113</b>
260 ... 600	S3	Black	4, 4X	yes	143D <b>3813</b>
260 ... 600	S3	Red/Yellow	4, 4X	yes	143E <b>3813</b>
260 ... 600	S3	Black	1, 3R, 12	yes	143F <b>3813</b>
260 ... 600	S3	Red/Yellow	1, 3R, 12	yes	143G <b>3813</b>
800 ... 1200	S4	Black	4, 4X	no	144D <b>3113</b>
800 ... 1200	S4	Black	1, 3R, 12	no	144E <b>3113</b>
800 ... 1200	S4	Black	1, 3R, 12	no	144F <b>3113</b>
800 ... 1200	S4	Red/Yellow	1, 3R, 12	no	144G <b>3113</b>
800 ... 1200	S4	Black	4, 4X	yes	144D <b>3813</b>
800 ... 1200	S4	Red/Yellow	4, 4X	yes	144E <b>3813</b>
800 ... 1200	S4	Black	1, 3R, 12	yes	144F <b>3813</b>
800 ... 1200	S4	Red/Yellow	1, 3R, 12	yes	144G <b>3813</b>

Use

The handle interlocking function prevents the user from opening the door of the enclosure when the switch is in the "ON" position. Opening the door when the switch is in the "ON" position is possible by defeating the interlocking function (not S5 and V handles) with the use of a tool (authorized persons only).

The interlocking function is restored when the door is re-closed.



Shaft for external handle

Rating (A)	Handle type	Length (in)	Length (mm)	Dimension X (in)	Dimension X (mm)	Reference
100 ... 400	S2	7.9	200	10 ... 14.3	254 ... 362	1400 <b>1020</b>
100 ... 400	S2	12.6	320	10 ... 19	254 ... 482	1400 <b>1032</b>
100 ... 400	S2	15.7	400	10 ... 22.1	254 ... 562	1400 <b>1040</b>
260 ... 400	S3	7.9	200	12 ... 18.4	305 ... 467	1401 <b>1520</b>
260 ... 400	S3	12.6	320	12 ... 23.1	305 ... 587	1401 <b>1532</b>
260 ... 400	S3	15.7	400	12 ... 26.3	305 ... 667	1401 <b>1540</b>
260 ... 600	S3	7.9	200	20 ... 23.4	508 ... 594	1401 <b>1520</b>
260 ... 600	S3	12.6	320	20 ... 28.1	508 ... 714	1401 <b>1532</b>
260 ... 600	S3	15.7	400	20 ... 31.3	508 ... 794	1401 <b>1540</b>
800 ... 1200	S4	7.9	200	20 ... 23.4	508 ... 594	1401 <b>1520</b>
800 ... 1200	S4	12.6	320	20 ... 28.1	508 ... 714	1401 <b>1532</b>
800 ... 1200	S4	15.7	400	20 ... 31.3	508 ... 794	1401 <b>1540</b>
800 ... 1200	V1 / S5	12.6	320	20 ... 28.1	508 ... 714	4199 <b>3018</b>
800 ... 1200	V1 / S5	15.7	400	20 ... 31.3	508 ... 794	4199 <b>3019</b>

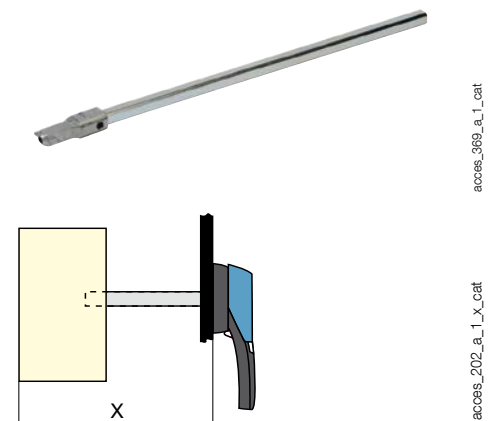

# SIRCOVER UL 98/1008

Manually operated transfer switching equipment  
from 100 to 1200 A

## Accessories (continued)

### Bridging bars

#### Use

Creation of a common point, above or below the switch, between positions I and II.  
Please check the numbers of poles needed.

Rating (A)	No. of poles	Reference
100 ... 200	2 P	4159 2021
100 ... 200	3 P	4159 3021
100 ... 200	4 P	4159 4021
260 ... 400	2 P	4159 2041
260 ... 400	3 P	4159 3041
260 ... 400	4 P	4159 4041
600	3 P	4159 3063
600	4 P	4159 4063
800 ... 1200	3 P	4159 3080
800 ... 1200	4 P	4159 4080



access\_205\_a\_1\_cat

### Terminal protection screen

#### Use

Top or bottom protection against direct contact with terminals or connecting parts.

Rating (A)	No. of poles	Reference
100 ... 200	2/3 P	4158 3021
100 ... 200	4 P	4158 4021
260 ... 400	2/3 P	4158 3041
260 ... 400	4 P	4158 4041
600	3 P	1609 3063
600	4 P	1609 4063
800 ... 1200	3 P	1609 3080
800 ... 1200	4 P	1609 4080



access\_207\_a\_1\_cat

### Auxiliary contacts

#### Use

Pre-break and signalization of positions.  
For low level ACs and other ACs contact us.

#### Electrical characteristics

A300.

#### NO/NC auxiliary contact

Rating (A)	Contact (s)	Reference
100 ... 400	NO/NC on position 1 and 2	4159 0021
100 ... 400	Low level NO/NC on position 1 and 2	4159 0022
600 ... 1200	NO/NC on position 1 and 2	as standard

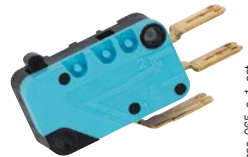

access\_065\_a\_1\_cat

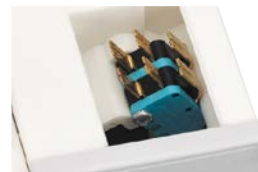

access\_065\_a\_1\_cat

### Terminal lugs

#### Use

Connection of bar copper cables onto the terminals (without lugs).

Rating (A)	Wires range	No wires per lug	Lugs per kit	Wires	Reference
100 ... 200	6 - 300MCM	1	2	Cu / Al	3954 2020
100 ... 200	6 - 300MCM	1	3	Cu / Al	3954 3020
100 ... 200	6 - 300MCM	1	4	Cu / Al	3954 4020
260 ... 400	4 - 600MCM	1	2	Cu / Al	3954 2040
260 ... 400	4 - 600MCM	1	3	Cu / Al	3954 3040
260 ... 400	4 - 600MCM	1	4	Cu / Al	3954 4040
600	2x (#2 - 600MCM)	2	3	Cu / Al	3954 3060
600	2x (#2 - 600MCM)	2	4	Cu / Al	3954 4060
800 ... 1200 <sup>(1)</sup>	2x 2x(#2 - 600MCM)	2	6	Cu / Al	3954 3120
800 ... 1200 <sup>(1)</sup>	2x 2x(#2 - 600MCM)	2	8	Cu / Al	3954 4120

<sup>(1)</sup> To be used to connect 4 wires on one terminal. In such a case, 2 lugs are placed side-by-side on one terminal. Please refer to dimensions diagram



ul\_032\_a

## Characteristics

### Characteristics according to UL 1008

General use rating (A)	100 A	200 A	260 A	400 A	600 A	800 A	1200 A
<b>Frame size</b>	<b>B4</b>		<b>B5</b>		<b>B6</b>	<b>B7</b>	
Operation voltage 2 P - 3/4 P	240/600	240/600	240/600	240/600	-/600	-/600	-/600
<b>Short circuit rating at 600 VAC with fuses (kA)</b>							
Short circuit rating at 600 VAC (kA)	100	100	65	65	100	100	100
Type of fuse	J	J	J	J	L	L	L
Max fuse rating (A)	200	400	600	600	800	1000	1600
<b>Short circuit rating at 600 VAC with "Specific Circuit Breaker" (kA)</b>							
Square D JJ breaker 250 A - 2 P 240 VAC - 3/4 P 480 VAC	65	65	-	-	-	-	-
Schneider Electric NSX-F 160 A - 3/4 P 480 VAC	35	-	-	-	-	-	-
<b>Short circuit rating at 600 VAC with "Any Breaker" (kA)</b>							
Short circuit rating (kA)	10	10	14	14	35	35	35
Short circuit capacity (ms)	25	25	50	50	50	50	50
<b>Rated operational current</b>							
240 VAC "Total System" (A)	100	200	260	400	400	700	700
240 VAC resistive load (A)	100	200	260	400	600	800	1200
480 VAC "Total System" (A)	100	100	260	400	350	600	600
480 VAC resistive load (A)	100	200	260	400	600	800	1200
600 VAC "Total System" (A)	100	100	200	200	-	-	-
600 VAC resistive load (A)	100	200	260	400	600	800	1200
<b>Mechanical endurance</b>							
Endurance (number of operating cycles)	6050	6050	6050	4050	3050	3050	3050
<b>Connection terminals</b>							
Min. connection section / AWG	#6	#6	#4 / 2 X 1 / 0	#4 / 2 X 1 / 0	2 x #2	2 x #2	4 x #2
Max. connection section / AWG	300MCM	300MCM	600MCM / 2 X 250MCM	600MCM / 2 X 250MCM	2x 600MCM	2x 600MCM	4 x 600MCM

### Characteristics according to UL 98/CSA 22.2#4

General use rating at 600 VAC and 250 VDC (A)	Specific reference upon request				600 A	800 A	1200 A
<b>Frame size</b>					<b>B6</b>	<b>B7</b>	
Short-circuit rating at 600 VAC (kA)	-	-	-	-	200	100	100
Type of fuse	-	-	-	-	J	L	L
Max. fuse rating (A)	-	-	-	-	600	800	1200
<b>Max. motor, hp / FLA 3 ph motor max.</b>							
220-240 VAC	-	-	-	-	200 / 480	-	-
440-480 VAC	-	-	-	-	400 / 477	-	-
600 VAC	-	-	-	-	500 / 472	-	-
<b>Mechanical characteristics</b>							
Endurance (number of operating cycles)	-	-	-	-	5000	3500	2500
Operating torque (lbs.in/Nm)	-	-	-	-	327.5/37	442.5/50	442.5/50
<b>Auxiliary contacts</b>							
Electrical characteristics	A300	A300	A300	A300	A300	A300	A300

## Mounting orientation

100 to 400 A / B4 - B5

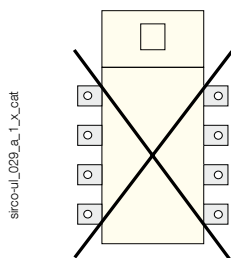

600 to 1200 A / B6 - B7

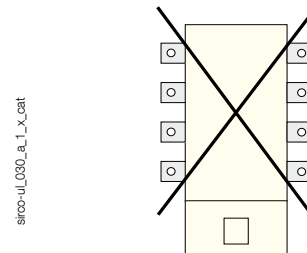





260 to 400 A / B5

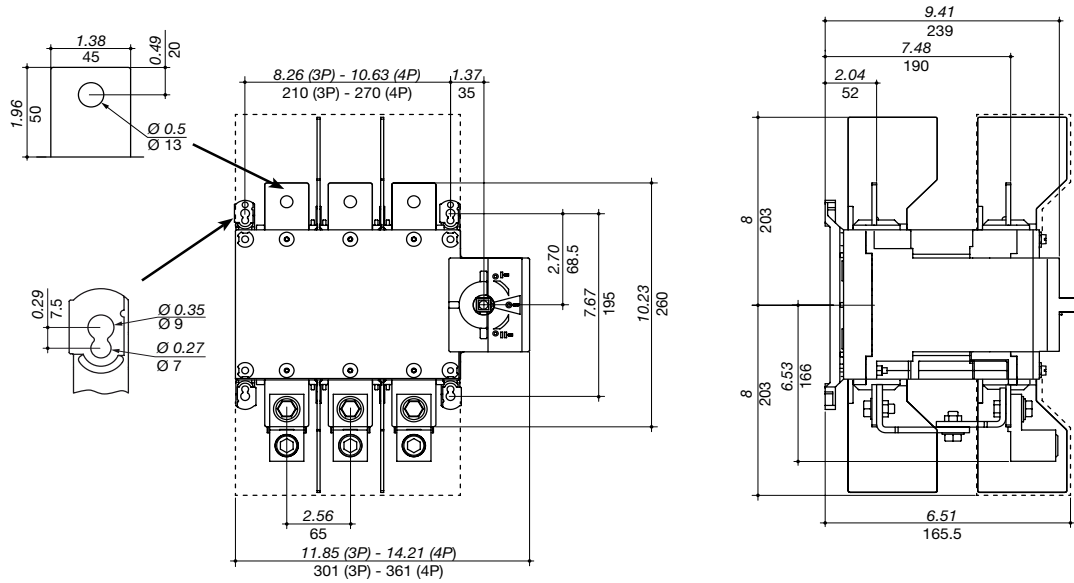

svr-ul\_016\_b\_1\_x\_cat

Minimum enclosure dimensions

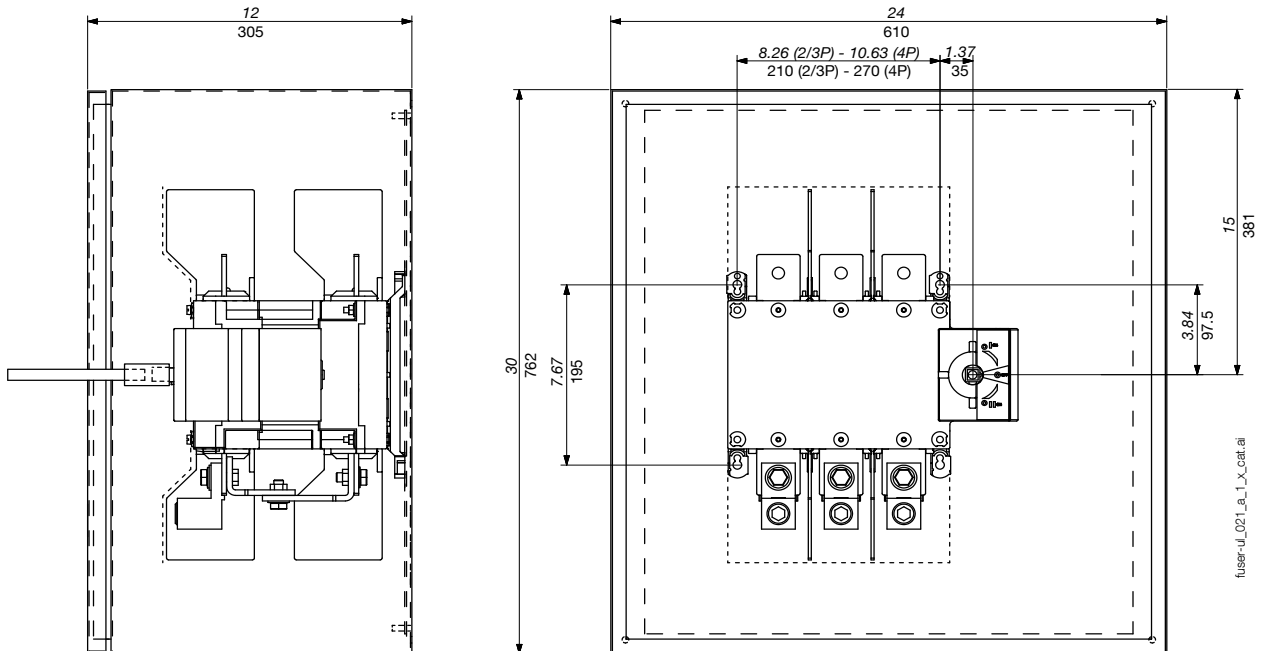

fuser-ul\_021\_la\_1\_x\_cat.ai

# SIRCOVER UL 98/1008

Manually operated transfer switching equipment  
from 100 to 1200 A

## Dimensions (in/mm) (continued)

600 A / B6

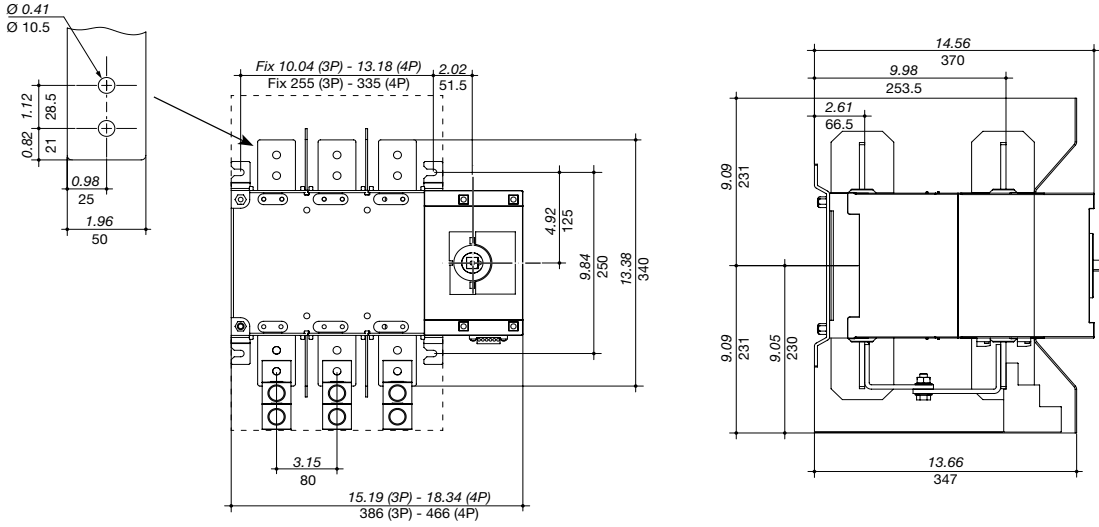

svr-ul\_003\_b\_1\_x\_cat

### Minimum enclosure dimensions

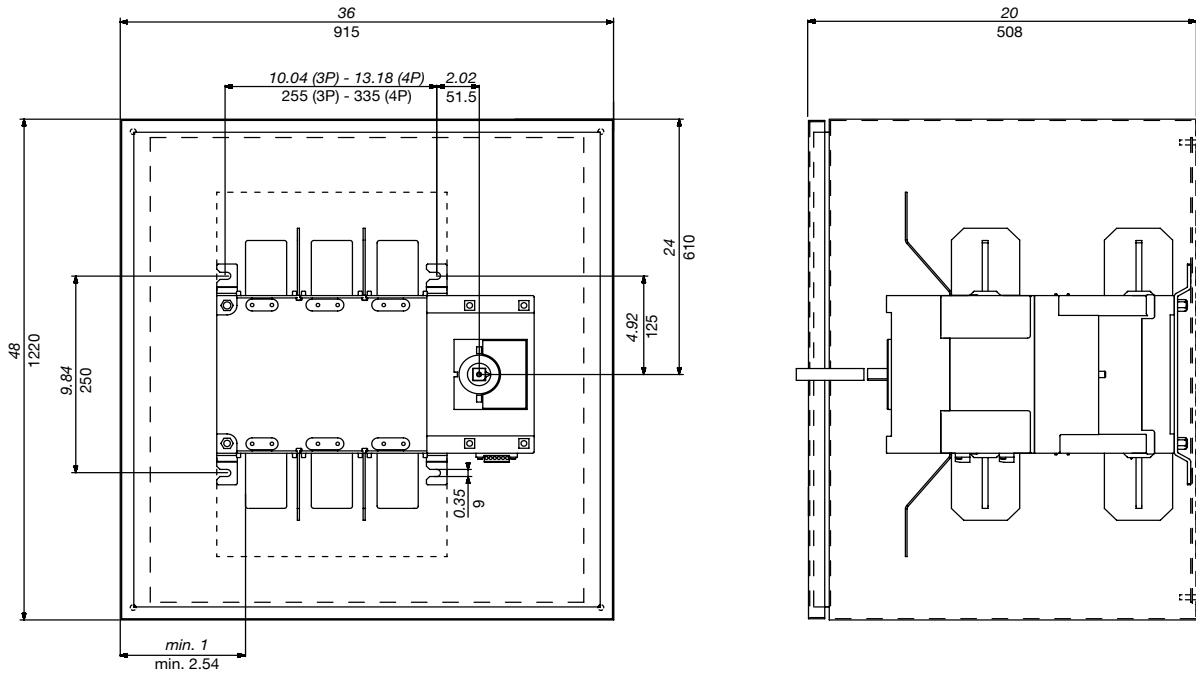

fuser-ul\_022\_a\_1\_x\_cat.ai

800 to 1200 A / B7

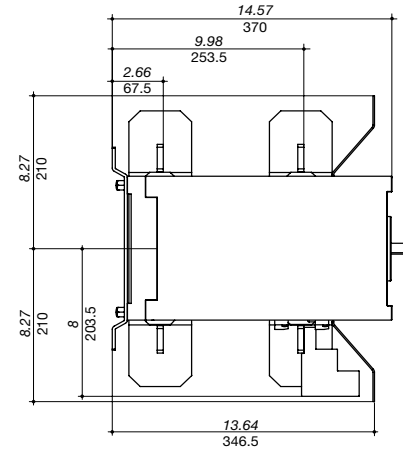
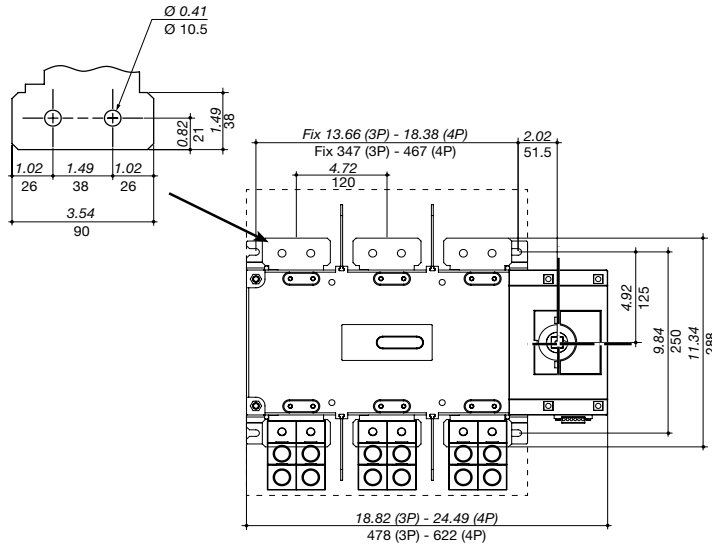

svr-ul\_004\_d\_1\_x\_cat

Minimum enclosure dimensions

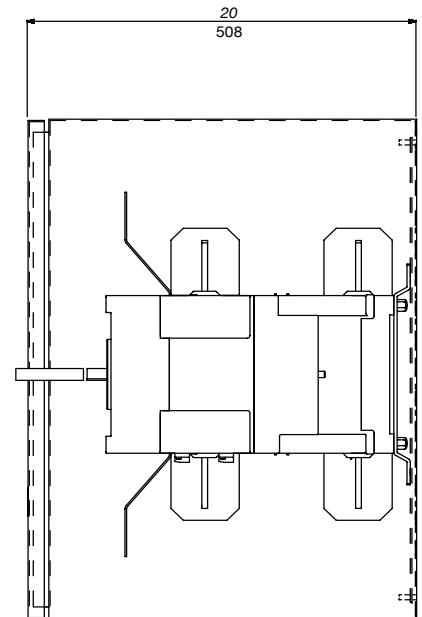
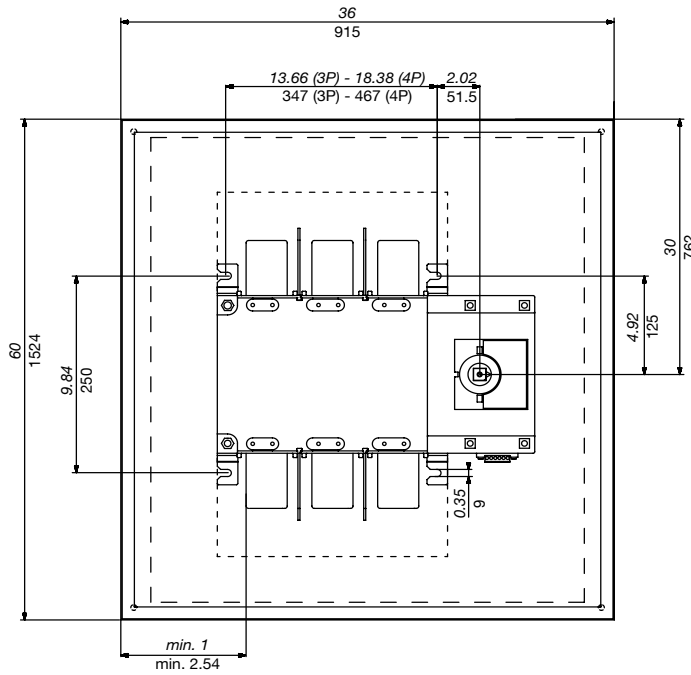

fuser-ul\_023\_a\_1\_x\_cat.ai



# ATyS C66

## UL ATS Controller

for Open and Delayed Transition

Transfer switches



ATyS C66



### Function

**ATyS C66** is an ATSE controller designed to control all types of emergency system, legally required and optional standby transfer switching equipment. The ATyS C66 is UL1008 listed with ATyS FT\* and ATyS DT\* power contactor switches as well as UR 1008 and UL 61010 listed for use with circuit breakers. ATyS C66 ensures automatic and manual transfer from one source to another with fully configurable timers and thresholds.

\* ATyS FT Fast Transfer, ATyS DT Delayed Transfer.

### Advantages

#### Fast commissioning

On initial power up, the ATyS C66's smart wizard will guide the operator through the commissioning process.

#### User customizable

Front panel LEDs, load shedding, engine exercisers and the elevator control signal are just some of the customizable features available on ATyS C66.

#### Intuitive operation

- The high-resolution LCD screen provides several dashboards enabling easy monitoring of all parameters, including power and energy consumption of the loads.
- The integrated energy backup provides transitional power to the product enabling status indication (switch position, timer status, fault notifications) and communication to remain active with no supply present.
- Quick and easy access to main functions through the front panel with direct key input.

### General characteristics

- Self-powered from voltage sensing.
- Wide voltage range (88 - 576 VAC).
- 24 VDC aux power supply (for optional use).
- 6 x 8 A programmable dry contact Form C outputs (SPDT) (2 latching relays).
- 6 x programmable inputs.
- DIN rail mountable I/O extension, up to 30 inputs and 18 outputs (accessory).
- Power & Energy metering with 1 or 5A current transformers.
- Up to 30 second energy backup.
- Smart wizard.
- 3000 Alarms and Events.
- Built-in engine exerciser with 4 independent programs.
- Associated Webserver software.
- In-phase transfer.

### References

Description	Reference
ATyS C66 controller	1600 <b>0066</b>
Diris Digiware IO-10 (4input/2 output) DIN-rail extension	4829 <b>0140</b>
Diris Digiware M-70 communications gateway for Ethernet & Webserver	4829 <b>0222</b>
DIRIS Digiware D-70 communication gateway for Ethernet & Webserver and multi-product display	4829 <b>0202</b>
Current Transformers	Consult us
ATyS FT / ATyS DT and cable harnesses	Consult us

### The solution for

- > Emergency systems
- > Legally required systems
- > Single & dual operator TSE



### Strong points

- > Self-powered
- > Built-in advanced features
- > Intuitive menus & Dashboards

### Conformity to standards

- > UL61010-2-201
- > UL61010-1
- > cURus 61010
- > cURus 1008



- > IEC 60947-6-1



### Communication gateways



DIRIS Digiware M-70 & D-70

Front panel

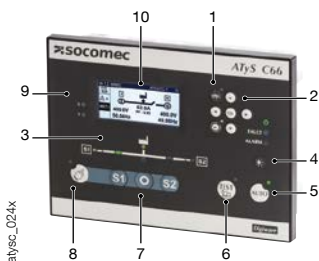

1. Dashboard displays.
2. Navigation keypad.
3. Mimic LED indication.
4. Lamp test button / LED info.
5. AUTO mode select.
6. TEST button.
7. CONTROL mode select.
8. Position orders (only in CONTROL mode).
9. Customizable LED.
10. Hi-res LCD screen.

Dimensions (in/mm)

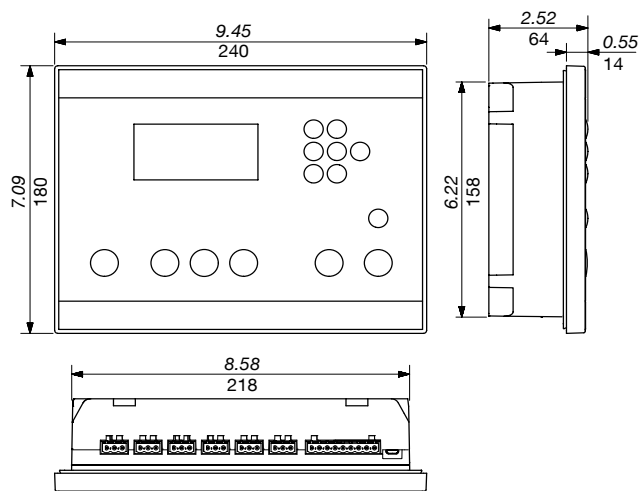

Characteristics

Electrical characteristics	
Operating AC limits	110 - 480 VAC ±20%
Optional DC supply	24 VDC
Frequency limits	45 - 65 Hz
Power consumption	< 10 W
Current transformers	1 or 5A
Measurement type	true RMS (TRMS)
Inputs	6 x fully programmable
Outputs	6 x form C, fully programmable
Output relays	8 A general use
I/O Extension (IO10)	up to 30 inputs and 18 outputs
Overvoltage category	CAT III
Impulse withstand	8/6 kV <sup>(1)</sup>

Mechanical characteristics	
Weight	2.38 lb / 1080 gr
Door cutout	8.66 x 6.3 in / 220 x 160 mm
Protection degree	IP65
Operating temperature	-22 ... +158 °F / -30 ... +70 °C
Communications	
Interface type	RS485. 2 to 3 half duplex wires
Protocol	MODBUS RTU
Baudrate	programmable 1200 - 115200 bps
Digiware bus cable	RJ45 specific cable
Display	
Screen resolution	350 x 160 pixels
Event recorder	3000 events

(1) 8 kV tested between phases of a different source and 6 kV tested between phases of a the same source.

Terminals

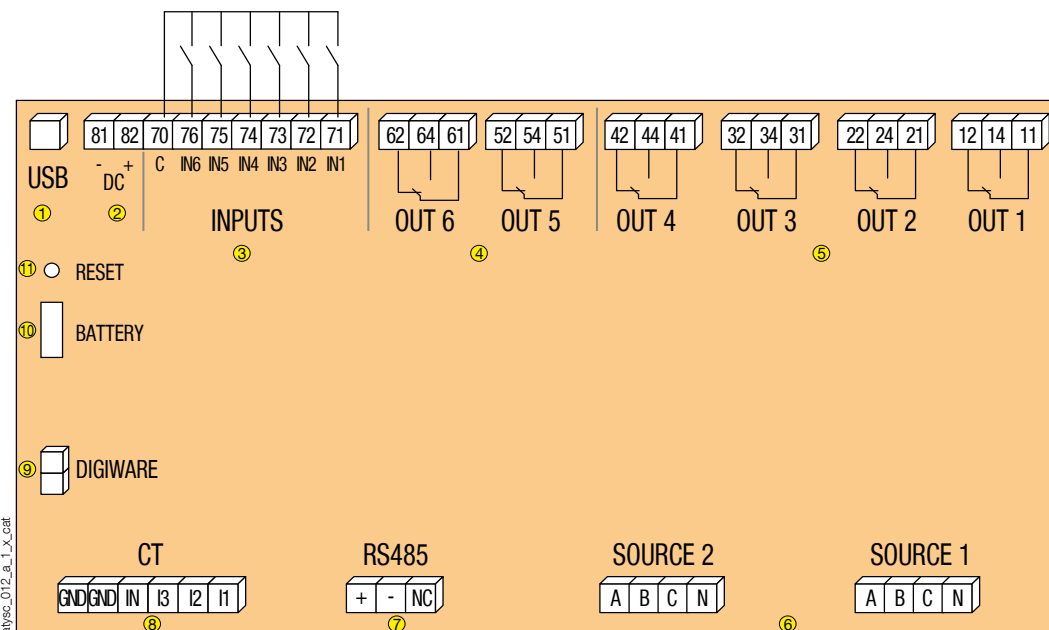

1. Configuration USB
2. 24 VDC aux power supply (for optional use)
3. 6 x inputs
4. 2 x latching relay outputs
5. 4 x relay outputs
6. Source sensing (110-480 ±20%)
7. RS485 communication
8. Current transformers (1 or 5 A)
9. Digiware RJ45 connectors
10. Replaceable RTC battery
11. Hard reset button



# Socomec: our innovations supporting your energy performance

**1** independent manufacturer

**3,600** employees  
worldwide

**10** % of sales revenue  
dedicated to R&D

**400** experts  
dedicated to service provision

## Your power management expert



POWER  
SWITCHING



POWER  
MONITORING



POWER  
CONVERSION



ENERGY  
STORAGE



EXPERT  
SERVICES

## The specialist for critical applications

- Control, command of LV facilities
- Safety of persons and assets
- Measurement of electrical parameters
- Energy management
- Energy quality
- Energy availability
- Energy storage
- Prevention and repairs
- Measurement and analysis
- Optimization
- Consultancy, commissioning and training

## A worldwide presence

**12** production sites

- France (x3)
- Italy (x2)
- Tunisia
- India
- China (x2)
- USA (x3)

**28** subsidiaries and commercial locations

- Algeria • Australia • Belgium • China • Canada
- Dubai (United Arab Emirates) • France • Germany
- India • Indonesia • Italy • Ivory Coast • Netherlands
- Poland • Portugal • Romania • Singapore • Slovenia
- South Africa • Spain • Switzerland • Thailand
- Tunisia • Turkey • UK • USA

**80** countries

where our brand is distributed

### SOCOMEK, Inc.

9 Galen Street, Suite 120  
Watertown, MA 02472  
Tel. 617 245 0447  
Fax 617 245 0437  
info.us@socomec.com

### YOUR DISTRIBUTOR / PARTNER

[www.socomec.us](http://www.socomec.us)

