



DIRIS A-40

Multi-function meters

Single-circuit metering
& monitoring



Configuration
with Easy Config System.



diris_989.psd

DIRIS A-40

Function

The DIRIS A-40 is a panel-mounted power monitoring device (PMD). It is designed for measuring, monitoring and reporting electrical energy.

Advantages

Assisted configuration

The configuration wizard guides the user in a step by step process to configure the DIRIS A-40. It also detects and corrects configuration errors. This cuts the commissioning time in half and always delivers a reliable result.

Smart sensors

Three current sensor formats (solid-core TE, split-core TR/ITR and Rogowski coil TF) allow integration of the DIRIS A-40 into new and existing electrical installations.

The DIRIS A-40 offers a range of functions for measuring voltage, current, power, energy and quality.

It allows the analysis of one single-phase or three-phase load.

Connected to the Cloud

The range comprises IoT ready connected products that enable data to be exported automatically for remote operation without any limit on time, distance and time in storage.

Better than revenue grade

Compliant with the IEC 61557-12 standard, guaranteeing the quality and accuracy of the Power Meter:

- Class 0.2 for the meter alone.
- Class 0.5 from 2% to 120% of the rated current (full scale), for the global measurement chain (with TE/ITR/TF current sensors).

The solution for

- > Industry
- > Building
- > Infrastructure
- > Data center



Strong points

- > Assisted configuration
- > Connected to the cloud
- > High-precision measurement chain
- > Smart sensors

Integrated technologies



Conformity to standards

- > UL 61010-1
CSA-C22.2
61010-1
File E257746
- > IEC 61557-12
- > ISO 14025
- > CEC compliant



Functions

Multi-measurement

- Currents
 - I1, I2, I3, In, Isystem
- Voltages & frequency
 - V1, V2, V3, VN, Vsystem, U12, U23, U31, Usystem, f
- Powers
 - P1, P2, P3, ΣP, Q1, Q2, Q3, ΣQ, S1, S2, S3, ΣS
 - Predictive powers ΣP, ΣQ, ΣS
- Power factor
 - PF1, PF2, PF3, ΣPF
- Cos φ & tangent φ
 - Instantaneous values per phase

Metering

- Active energy: +/- kWh
- Reactive energy: +/- kvarh
- Apparent power: kVAh
- Multi-tariff (8 max.)
- Hour Meter

Quality

- Voltage Unbalance
 - Vdir, Vinv, Vhom, Udir, Uinv, Unba, Vnba, Vnb, Unb
- Current unbalance
 - Idir, linv, lhom, Inba, Inb
- Total harmonic distortion
 - Currents THDi1, THDi2, THDi3, THDiN, TDDI
 - Phase-to-neutral voltage THDv1, THDv2, THDv3
 - Phase-to-phase voltage THDu12, THDu23, THDu31
- Individual harmonics up to 63rd
 - Currents: I1h, I2h, I3h, INh
 - Phase-to-neutral voltage: V1h, V2h, V3h
 - Phase-to-phase voltage: U12h, U23h, U31h
- Quality events
 - Voltage sags, interruptions and swells EN50160
 - K factor & Crest factor
- Events according to EN 50160
 - Voltage sags, interruptions, voltage swells
- Waveform capture
 - Automatic waveform captures when event occurs, and manual recording of the waveform
 - Available through communication

Monitoring of protective devices

- Auxiliary contact monitoring
- Report and alarm on trips
- Number of operations

Demand profiles and historical records

- Active, reactive and apparent power
- Currents, voltages and frequency

Alarms

- Alarms for all electrical values, events and input status changes, boolean combinations of multiple alarms
- Time-stamping of events

Communication

- DIRIS A-40 RS485 Modbus as standard
- DIRIS A-40 Ethernet Modbus
- DIRIS A-40 PROFIBUS DPV1

Inputs

- 3 digital inputs
 - Power supplied from DIRIS A-40 or an external source
 - Function: logical status, status of circuit breaker, pulse metering of multifluid meters.
- 2 logical outputs
 - Function: Command, energy pulse output, load shedding, alarm

Functions

Monitoring

- Real-time measurement of electrical values.
- View data as graphs or tables.
- Power quality analysis of the utility supply and of loads.



soft_027_a_1_fr_cateps

Metering

- Measurement of active, reactive and apparent energies.
- Historical record of measurements.
- Graphic display on monthly, weekly, daily or hourly basis.



Alarming

- Display of alarms.
- History of alarms.



soft_036_a_1_fr_cateps

soft_025_a_1_fr_cateps

Terminals

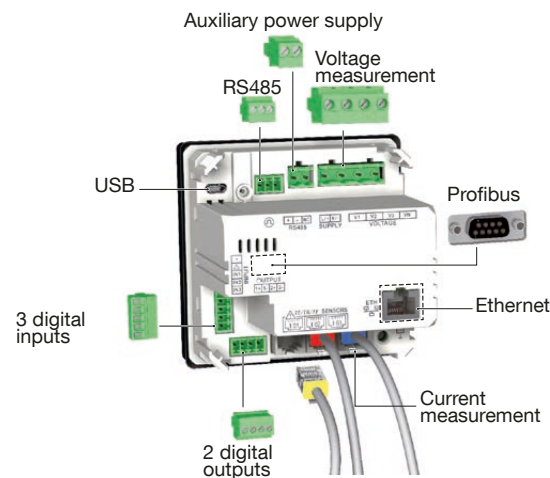

diris_968_a_1_en_catal

Dimensions (in/mm)

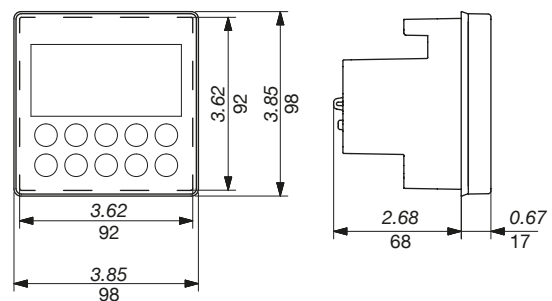

diris_967_a_1_us.ai

Current measurement

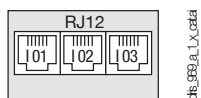

diris_980_a_1_x_catal

3 inputs supplied by the product

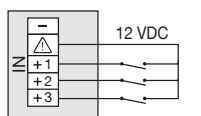

diris_971_a_1_x_catal

3 inputs with external power supply

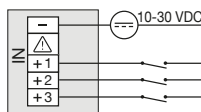

diris_972_a_1_x_catal

Voltage connections inc auxiliary power supply

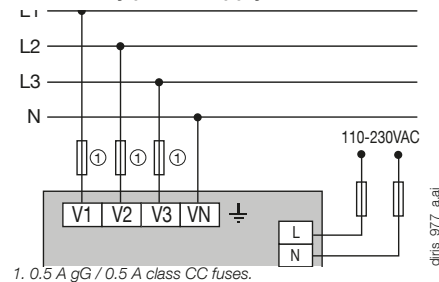

diris_977_a.ai

RS485

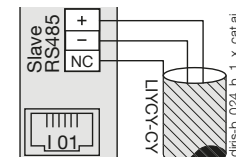

diris-b_024_b_1_x_catal

2 outputs

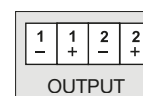

Earth



DIRIS A-40

Multi-functions meters

Connections

Associated current sensors

Various types of current sensors can be connected to the DIRIS A-40: solid-core (TE), split-core (TR/iTR) or Rogowski (TF). This range of sensors is suitable for all types of new or existing installations. A quick RJ12 connection makes wiring easy and reliable and prevents wiring errors. The DIRIS A-40 automatically recognizes the sensor type and rating. This guarantees the overall accuracy of the DIRIS A-40 + current sensor measurement chain.

TE solid-core current sensors

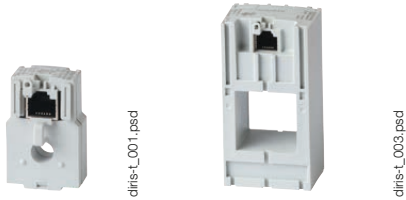

TR/iTR split-core current sensors



TF Rogowski current sensors



TE / TR/iTR / TF current sensors

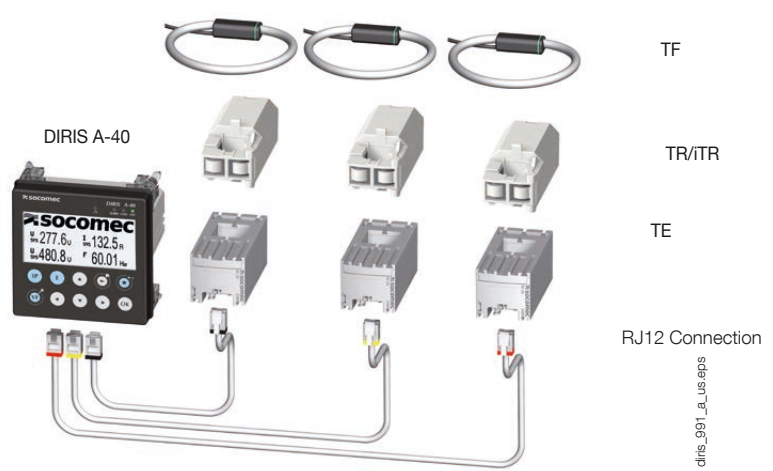

Network and connection examples

Three phase + Neutral

3P+N - 3 CT (1 three-phase load + calculated Neutral)

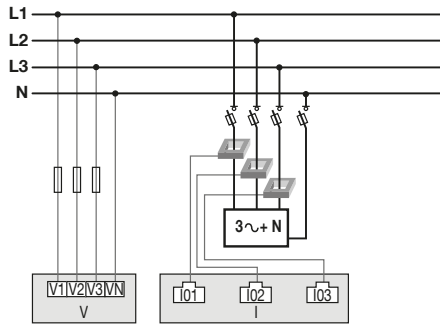

diris_973_a.ai

Three-phase

3P - 3CT (1 three-phase load)

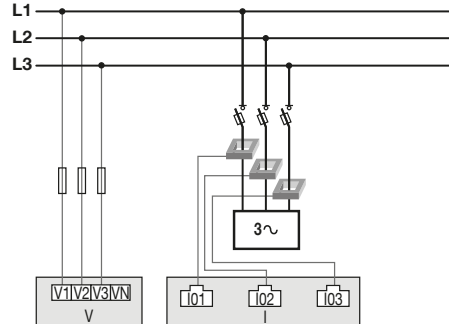

diris_974_a.ai

Three-phase

3P - 1CT (1 balanced three-phase load)

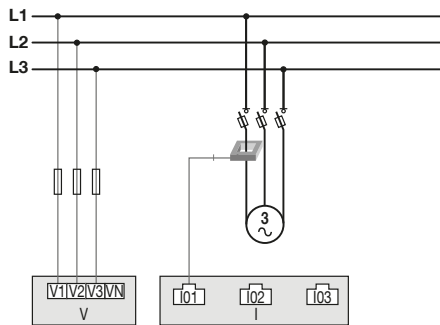

diris_975_a.ai

Single-phase

1P+N - 1CT (1 single-phase load)

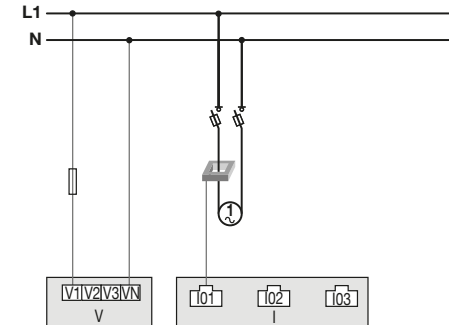

diris_976_a.ai

1.0.5 A class CC fuses.

If self-supplied, a fuse must always be added to the Neutral.



DIRIS A-40 characteristics

Electrical characteristics

Auxiliary power supply	
Alternative voltage	110/400 VAC or 120/300 VDC - Cat III
Frequency	50/60 Hz
Power consumption	5 VA AC / 1.5 VA DC (4825 0500) 8 VA AC / 2.5 VA DC (4825 0501 & 4825 0502)
Connection	Removable spring-cage terminal block, 2 x 2 positions, AWG 10 ... 24 / 0.5 ... 2.5 mm ² solid cable or AWG 15 ... 30 / 0.25 ... 1.5 mm ² stranded cable with ferrule

Measurement characteristics

Power and energy measurement	
Accuracy	Class 0.2 for the DIRIS A-40 stand alone
Active energy and active power	Class 0.5 with TE, TF or ITR sensors Class 1 with TR sensors
Accuracy of reactive energy	Class 2 with TE, TR or TF sensors

Power factor measurement

Accuracy	Class 0.5 with TE, TF or ITR sensors Class 1 with TR sensors
----------	---

Voltage measurement

Characteristics of the network measured	50-300VAC (Ph/N) - 87-520VAC (Ph/Ph) - CAT III
Frequency range	45 to 65Hz
Frequency accuracy	Class 0.02
Network type	Single-phase/ Two-phase / Two-phase with neutral / Three-phase / Three-phase with neutral
Measurement by voltage transformer	Primary: 400,000 VAC Secondary: 60, 100, 110, 173, 190 VAC
Input consumption	≤ 0.1 VA
Accuracy of voltage measurement	Class 0.2
Connection	Removable spring-cage terminal block, 4 positions, AWG 10 ... 24 / 0.5 ... 2.5 mm ² solid cable or AWG 15 ... 30 / 0.25 ... 1.5 mm ² stranded cable with ferrule

Current measurement

Number of current inputs	3
Associated current sensors	Solid TE, split-core TR/TR, flexible TF current sensors
Accuracy	0.2 DIRIS A-40 class only Class 0.5 with TE, TF or ITR sensors Class 1 with TR sensors
Connection	Specific Socomec cable with RJ12 connectors

Input characteristics

Number	3
Type / Power supply	Optocoupler with internal (12 VDC ± 10%) or external (12-24 VDC ± 20%) polarisation
Input function	Logical status, protective device monitoring, pulse metering of multifluid meters.
Connection	Removable screw terminal block, 5 positions, AWG 15 ... 35 / 0.14 to 1.5 mm ² stranded or solid cable

Output characteristics

Number	2
Type	Optocoupler 30 Vd.c. max 20mA max - SELV
Output function	Command, energy pulse output, load shedding, alarm
Connection	Removable screw terminal block, 4 positions, AWG 15 ... 35 / 0.14 to 1.5 mm ² stranded or solid cable

Communication characteristics

Communication	
Ethernet RJ45 10/100 Mbs	Gateway function Modbus TCP BACnet IP SNMP v1, v2, v3
RS485 2-3 wires	Modbus RTU communication function Configurable as input or output

Environmental specifications

Storage temperature	-4 ... +158 °F / -20 °C ... +70 °F
Operation temperature	+14 ... +131 °F / -10 °F ... +55 °F
Humidity	95% at 104 °F / 40 °C
Installation category, degree of pollution	CAT III, 2

References

DIRIS A-40 monitoring devices		Reference
DIRIS A-40	RS485 Modbus - 3 inputs / 2 outputs	4825 0500
DIRIS A-40	Ethernet Modbus TCP or Bacnet IP - webservice - RS485 Modbus - 3 inputs / 2 outputs	4825 0501
DIRIS A-40	Profibus DPV1 - RS485 Modbus - 3 inputs / 2 outputs	4825 0502

Expert Services

- > Our local team offers complete support to ensure the success of your project, from consultation to implementation of your metering system.

