

DIRIS Digiware I

Current acquisition module

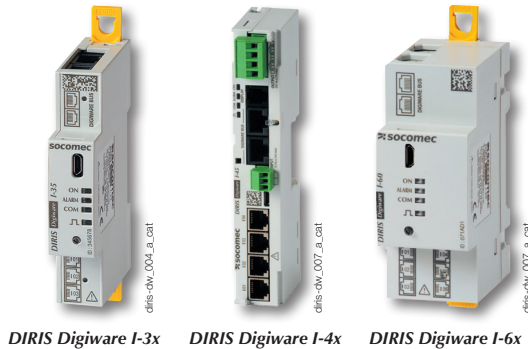

Function

DIRIS Digiware I are DIN-rail mounted power monitoring modules. Associated with DIRIS Digiware U modules, they measure and monitor electrical parameters such as powers, energies and power quality of electrical installations.

The modularity, along with the RJ45 Digiware Bus provides a unique multi-circuit and scalable approach. Adding DIRIS Digiware I modules to the bus is done simply by clicking in an RJ45 cable. This allows great flexibility to users who wish to add more metering points in the future.

The RJ12 current inputs allow a quick and error-free connection to current sensors (TE, TR/iTR, TF) with automatic detection of the type and rating of the current sensors connected. This ensures reliable and accurate measurements at all times.

Advantages

Multi-circuit

- One module can monitor up to 2 three-phase circuits.
- Up to 31 current measurement modules can be added to the Digiware Bus, allowing to monitor a large number of circuits within the same DIRIS Digiware system.

Plug & Play

- RJ45 cables for a quick and easy connection of modules.
- Color-coded RJ12 cables to connect current sensors, quickly, safely and without errors.
- Load type, current sensor type and rating are automatically detected.
- When connected to iTR current sensors, the AutoCorrect technology detects and corrects wiring errors, making the system more reliable.

Accurate

- Compliant with standard IEC 61557-12, guaranteeing the quality and accuracy of measurements:
- class 0.5 from 2 - 120% In for the global measurement chain (including TE/ iTR/TF current sensors)
- class 1 from 2 - 120% In for the global measurement chain (including TR current sensors)

Flexible

- Modules available in 3, 4 or 6 current sensor inputs.
- The types of current modules can be mixed within the Digiware system, to monitor a variety of single-phase, two-phase and three-phase circuits.

The solution for

- > Industry
- > Building
- > Infrastructure
- > Data center



Strong points

- > Multi-circuit
- > Plug & Play
- > Accurate
- > Flexible

Integrated technologies



For more information see our website www.socomec.us

Conformity to standards







- > UL 61010-1, CSA-C22.22 No. 61010-1, Guide FTRZ/PICQ, File E257746
- > ANSI C12.20
- > PBI Meter per CA Energy Commission
- > IEC 61557-12



Create your project

- > Find the best DIRIS Digiware configuration: www.meter-selector.com



Application	Current measurement modules						
	Metering		Analysis	Monitoring	Analysis	Metering	
							
DIRIS Digiware I	I-30	I-31	I-35	I-43	I-45	I-60	I-61
General							
Number of current inputs	3	3	3	4	4	6	6
Inputs / Outputs							
Digital inputs / outputs				2 / 2	2 / 2		
Metering							
± kWh, ± kvarh, kWh	•	•	•	•	•	•	•
ΣP (kW), ΣQ (kvar), ΣS (kVA), PF	•	•	•	•	•	•	•
P (kW), Q (kvar), S (kVA), PF per phase		•	•	•	•		•
Predictive Power			•		•		
Load curves / demand profiles		•	•		•		•
Peak Demand			•	•	•		
Multi-tariff			8		8		
Multi-measurement							
I1, I2, I3, In	•	•	•	•	•	•	•
I system			•		•		
Current unbalance (Inba, Idir, linv, Ihom, Inb)			•		•		
Phi, cos Phi, tan Phi			•		•		
Power Quality							
THD I1, I2, I3, In			•	•	•		
Individual harmonics 1 (up to 63rd)			•		•		
Crest factors I1, I2, I3, In			•		•		
K Factor			•		•		
I/O							
Digital Inputs							
Digital Outputs							
Alarms							
Overcurrents		•	•		•		•
Measurement threshold		Power / Energies	•		•		Power / Energies
System alarms	•	•	•	•	•	•	•
Protective device	with ITR sensors	with ITR sensors	with ITR sensors	with ITR sensors	with ITR sensors	with ITR sensors	with ITR sensors
Logical (digital input status change)				•	•		
History							
Average values			•		•		
Reference	4829 0110	4829 0111	4829 0130	4829 0129	4829 0131	4829 0112	4829 0113

Accessories

Digiware plug-in connector

With the Digiware plug-in connector you can disconnect a DIRIS Digiware module from the Digiware bus while ensuring the DIRIS Digiware system continues to run downstream.

This accessory is particularly useful in applications with retractable drawers or critical applications such as data centers with busway systems.



diris-e-0215.eps

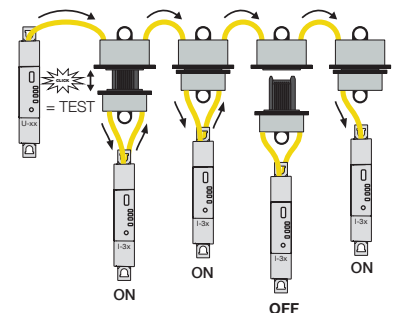

diris-e-0216_a1_1_cst.tif

Dimensions (in/mm)

DIRIS Digiware I-3x / I-6x

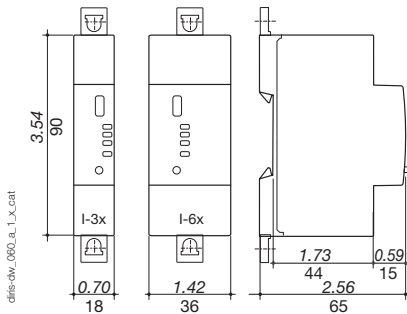

DIRIS Digiware I-4x

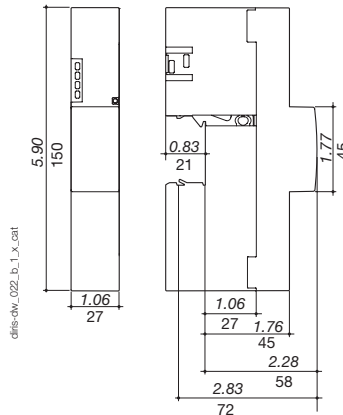

Current sensors

Various types of current sensors can be connected to the DIRIS Digiware I: Solid-core TE, split-core TR/TR, flexible TF current sensors. This range of sensors can be adapted to all types of new or existing installations. A rapid RJ12 connection makes wiring easy and reliable and prevents wiring errors. The DIRIS Digiware I meter module automatically recognizes the type of sensor used and its current rating. This guarantees the accuracy of the overall measurement chain (DIRIS Digiware I + current sensors).

For more information see "TE, TR and TF sensors" pages.

I-3x

Three-phase

3P - 3CT (1 three-phase load)

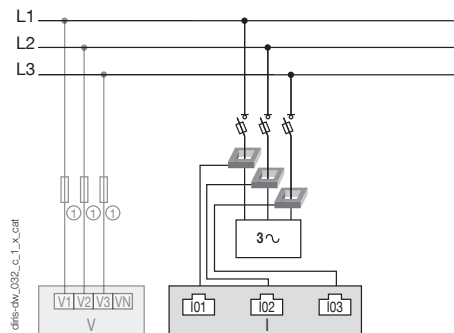

Three-phase

3P - 1CT (3 balanced, three-phase loads)

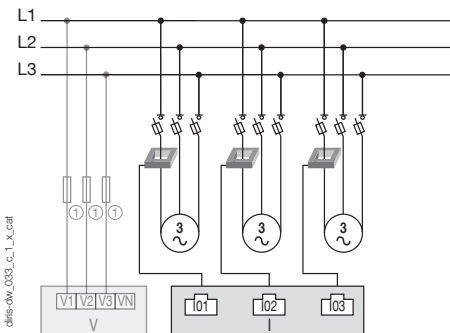

I-4x

Three phase + neutral

3P+N - 4CT (1 three-phase load + Neutral measured)

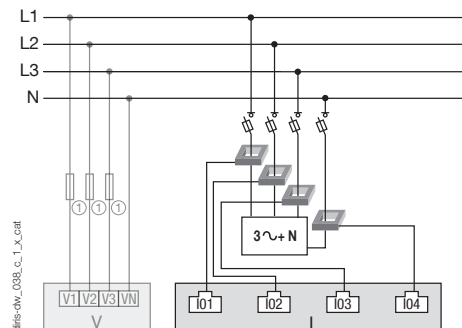

1. 0.5 A gG / 0.5 A class CC fuses.

Single-phase

1P+N-1CT (4 single-phase loads)

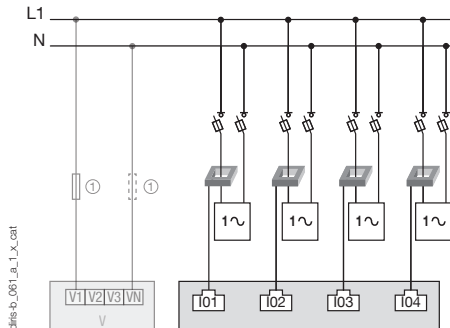

CT: Current sensor 3~ Load

Technical Characteristics

Mechanical characteristics	
Mounting type	DIN-rail or back plate
Ingress Protection	IP20, front face

Measurement characteristics	
Current measurement	
Number of current inputs	I-3x: 3 / I-45: 4 / I-6x: 6
Associated current sensors	Solid-core TE, split-core TR/iTR, flexible TF current sensors
Connection type	Socomec RJ12 cables
Current measurement accuracy	Class 0.2 DIRIS Digiware I alone Class 0.5 with TE, iTR, TF sensors Class 1 with TR sensors

Power and Energy measurement	
Active Power/Energy accuracy	Class 0.2 DIRIS Digiware I alone Class 0.5 with TE, iTR, TF sensors Class 1 with TR sensors
Reactive Power accuracy	Class 1 with TE, iTR, TF sensors Class 2 with TR sensors
Reactive Energy accuracy	Class 2 with TE, TR/iTR, TF sensors

Digital inputs - DIRIS Digiware I-4x	
Number of digital inputs	2
Digital input type	Non-insulated input, internal polarization 12 VDC max, 1mA
Function	Logical status, pulse meter, multi-tariff
Connection	Removable screw terminal block, 4 positions, AWG 16 to AWG 26 / 0.2 to 1.5 mm ² stranded or solid cable

Digital outputs - DIRIS Digiware I-4x	
Number of digital outputs	2
Relay type	230 VAC ±15% - 1 A 30 VDC - 3 A
Function	Manual command, alarm report
Connection	Removable screw terminal block, 4 positions, AWG 14 to AWG 24 / 0.2 to 2.5 mm ² stranded or solid cable

Communication characteristics	
Digiware Bus	
Connection type	Socomec RJ45 cable
Function	Proprietary bus connecting Digiware units
USB	
Connection type	USB Type Micro-B
Protocol	Modbus RTU over USB
Function	Firmware upgrade and configuration

Environmental characteristics	
Storage temperature	-4 to +158 °F / -20 to +70°C
Operating temperature	+14 to +158 °F / -10 to +70°C
Humidity	0% to 97% RH / +131°F/+55°C, non condensing
Operating altitude	≤ 6560 ft / 2000 m

References

DIRIS Digiware I	Reference
I-30 Metering - 3 current inputs	4829 0110
I-31 Metering + demand profiles - 3 current inputs	4829 0111
I-35 Analysis - 3 current inputs	4829 0130
I-43 Monitoring - 2 inputs/ 2 outputs - 4 current inputs	4829 0129
I-45 Analysis - 2 inputs/ 2 outputs - 4 current inputs	4829 0131
I-60 Metering - 6 current inputs	4829 0112
I-61 Metering + demand profiles - 6 current inputs	4829 0113

Accessories	Reference
Digiware Plug-in connectors (box of 5)	4829 0605
Digiware Bus terminating resistor (already supplied with DIRIS Digiware C, M & D)	4829 0180
1A/5A secondary CT adapter with RJ12 output	4829 0599
6.5-ft USB Cable for configuration - Type A to Type Micro-B	4829 0050

Digiware bus cables ⁽¹⁾	Reference	
RJ45 cables for Digiware Bus	Length 0.20 ft / 0.06 m	4829 0189
	Length 0.32 ft / 0.10 m	4829 0181
	Length 0.66 ft / 0.20 m	4829 0188
	Length 1.64 ft / 0.50 m	4829 0182
	Length 3.28 ft / 1 m	4829 0183
	Length 6.56 ft / 2 m	4829 0184
	Length 9.84 ft / 3 m	4829 0190
	Length 16.4 ft / 5 m	4829 0186
Length 32.8 ft / 10 m	4829 0187	
164.04 ft / 50 m reel + 100 connectors	4829 0185	

⁽¹⁾ To guarantee the proper operation of the DIRIS Digiware system, do not substitute Socomec Digiware bus cables with standard Ethernet RJ45 cables.

References (continued)

RJ12 Solid-core current sensors ⁽¹⁾

Model	Nominal current range (A)	Real range covered (A)	Window size (in/mm)	Reference
TE-18	5 ... 20	0.1 ... 24	∅ 0.33 / 8.6	4829 0500
TE-18	25 ... 63	0.5 ... 75	∅ 0.33 / 8.6	4829 0501
TE-25	40 ... 160	0.8 ... 192	0.53 x 0.53 / 13.5 x 13.5	4829 0502
TE-35	63 ... 250	1.26 ... 300	0.82 x 0.82 / 21 x 21	4829 0503
TE-45	160 ... 630	3.2 ... 756	1.22 x 1.22 / 31 x 31	4829 0504
TE-55	400 ... 1000	8 ... 1200	1.61 x 1.61 / 41 x 41	4829 0505
TE-90	600 ... 2000	12 ... 2400	2.52 x 2.52 / 64 x 64	4829 0506

(1) Refer to pages 348-351 for more information on TE current sensors

RJ12 Split-core current sensors ⁽²⁾

Model	Nominal current range (A)	Real range covered (A)	Window size (in/mm)	Reference
TR-10 / iTR-10	25 ... 63	0.5 ... 75.6	∅ 0.39 / 10	4829 0555 / 4829 0655
TR-14 / iTR-14	40 ... 160	0.8 ... 192	∅ 0.55 / 14	4829 0556 / 4829 0656
TR-21 / iTR-21	63 ... 250	1.26 ... 300	∅ 0.83 / 21	4829 0557 / 4829 0657
TR-32 / iTR-32	160 ... 600	3.2 ... 720	∅ 1.26 / 32	4829 0558 / 4829 0658

(2) Refer to pages 352-353 for more information on TR/iTR current sensors

RJ12 Flexible Rogowski current sensors ^{(3) (4)}

Model	Nominal current range (A)	Real range covered (A)	Window size (in/mm)	Reference
TF-40	100 ... 400	2 ... 480	∅ 1.57 / 40	4829 0573
TF-80	150 ... 600	3 ... 720	∅ 3.15 / 80	4829 0574
TF-120	400 ... 2000	8 ... 2400	∅ 4.72 / 120	4829 0575
TF-200	600 ... 4000	12 ... 4800	∅ 7.87 / 200	4829 0576
TF-300	1600 ... 6000	32 ... 7200	∅ 11.81 / 300	4829 0577
TF-600	1600 ... 6000	32 ... 7200	∅ 23.62 / 600	4829 0578
Set of 3 RJ12 female/female connectors for RJ12 lead extension between power meter and TF sensor				4829 0670

(3) TF Rogowski sensors come with a 6-ft cable lead with RJ12 male connector

(4) Refer to pages 354-355 for more information on TF current sensors

RJ12 sensor lead cables	Cable length (ft / m)										164/50 reel + 100 connectors
	0.32/0.1	0.64/0.2	0.96/0.3	1.64/0.5	3.3/1	6.5/2	9.84/3	16.4/5	22.9/7	32.8/10	
Number of cables	Reference	Reference	Reference	Reference	Reference	Reference	Reference	Reference	Reference	Reference	Reference
1	-	-	-	-	-	-	-	4829 0602	-	4829 0603	4829 0601
3	4829 0580	4829 0581	4829 0582	4829 0595	4829 0583	4829 0584	4829 0606	4829 0607	4829 0608	4829 0609	-
4	-	-	-	4829 0596	4829 0588	4829 0589	-	-	-	-	-
6	4829 0590	4829 0591	4829 0592	4829 0597	4829 0593	4829 0594	-	-	-	-	-

Commissioning		Reference
1/2 day remote commissioning	Remote commissioning including installation verification, programming and communication testing	9230100027
1/2 day on-site commissioning	On-site commissioning including installation verification, programming and communication testing	9230100004

Expert Services

Our service engineers are an essential part of our team, and they are dedicated to ensuring your power monitoring system provides accurate and reliable measurements to your EPMS software or SCADA system.

Our services include:

- > Site audits to verify the proper wiring of your system
- > Personnel training on how to configure, operate and maintain power monitoring equipment and associated software
- > Remote and on-site commissioning to ensure that your system is up and running quickly, with peace of mind.

For further information, please contact your nearest SOCOMEC branch.

